

DO it

Wie für Sie gemacht!



ORIGINE
FRANCE®
GARANTIE

BVCert. 6164725

ERARD®

FiXiT 200

- Festsehende Halterung für 19" bis 32" Flachbildschirme
- Getestet bis 150 kg

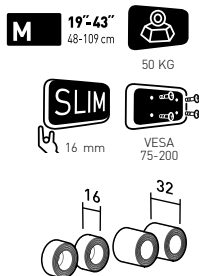
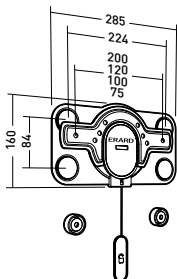
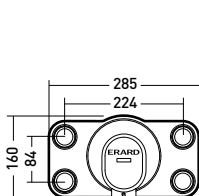

FiXiT 400

- Festsehende Halterung für 30" bis 55" Flachbildschirme
- Getestet bis 200 kg

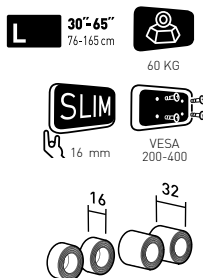
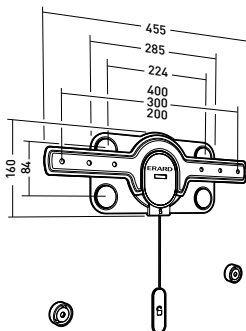
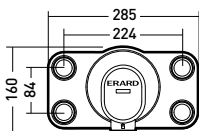

FiXiT 600

- Festsehende Halterung für 40" bis 75" Flachbildschirme
- Getestet bis 280 kg

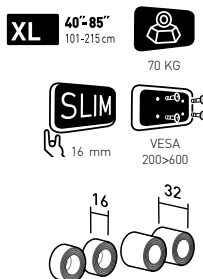
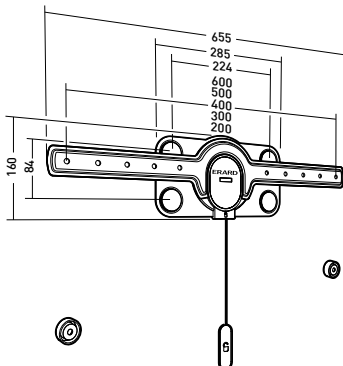
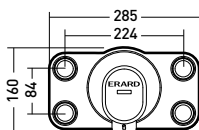

**10 JAHRE
GARANTIE**

TiLTiT / TWiSTiT

Technische Eigenschaften

TiLTiT 400

- Neigbare Halterung für 30" bis 55" Flachbildschirme
- Getestet bis 120 kg

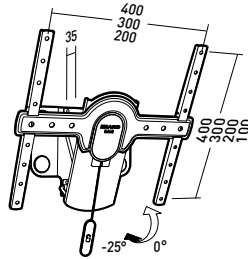
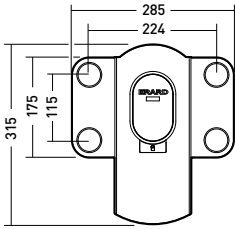

L 30"-65"
76-165 cm



30 KG



0>25°



VESA
200-400



SLIM
35 mm



MAX. TIEFE
50 mm

TWiSTiT 400

- Neig- und schwenkbare Halterung für 30" bis 55" Flachbildschirme
- Getestet bis 120 kg

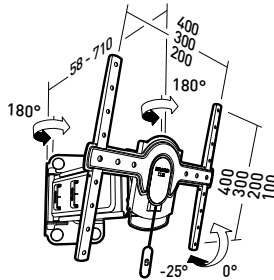
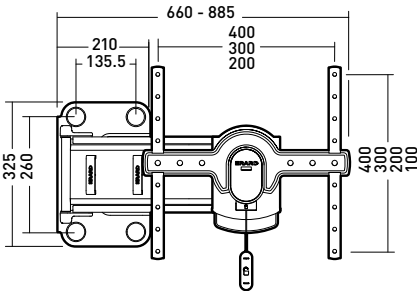

L 30"-65"
76-165 cm



30 KG



0>25°



VESA
200-400



-90°>+90°



SLIM
58 mm



MAX. TIEFE
50 mm

Teleskoparm mit
integrierter
Messkala

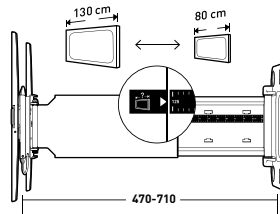

RAUMECKE
INSTALLATION
MÖGLICH

Sortiment DO iT

Das gesamte Sortiment
für Flachbildschirme

M 19"-43"
48-109 cm

L 30"-65"
76-165 cm

XL 40"-85"
101-215 cm

19" 30" 40" 43" 65" 85"

TWISTIT 400
NEIG- UND SCHWENKBAR



044440

TILTIT 400
NEIGBAR



044240

FIXIT
FESTE INSTALLATION



044020



044040



044060

ERARD®

NÜTZLICHES ZUBEHÖR
FÜR AUDIO- UND VIDEOGERÄTE

Mail : export@erard.fr / www.erard.com / Tel : +33 (0)4 72 46 16 26 / Fax : +33 (0)4 72 46 16 22

Ust.-IdNr.: FR 81 403 591 415

Z.I. de Chavanoz / 4 route de la Plaine / 338230 CHAVANOZ / FRANCE

