

SP730P	SmartMount® Pivoting Wall Mount for 10" to 29" Displays
---------------	---

Product Specifications

	DIMENSIONS (W x H x D)	PRODUCT WEIGHT	LOAD CAPACITY	FINISH	AVAILABLE COLORS
SP730P	11.14" x 8.06" x 2.77"-9.88" (283 x 205 x 70-251mm)	2.45lb (1.1kg)	25lb (11kg)	Scratch resistant fused epoxy	Semi-gloss black

Package Specifications

	PACKAGE SIZE (W x H x D)	PACKAGE SHIP WEIGHT	PACKAGE UPC CODE	PACKAGE CONTENTS	UNITS IN PACKAGE
SP730P	14.13" x 3.75" x 10.38" (359 x 95 x 264mm)	3.75lb (1.7kg)	735029237365	Wall mount, wall and display installation hardware, installation instructions	1

Accessories

- ACC918:** Security Fasteners
- ACC2X4:** VESA® 200 x 100mm Adaptor Plate
- WSP700/WSP701:** Metal Stud Wall Plates for 16"/24" Center Metal Studs

All dimensions = inch (mm)

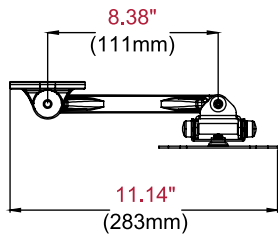

TOP VIEW

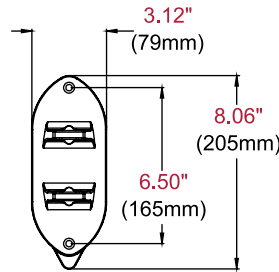

WALL PLATE DETAIL

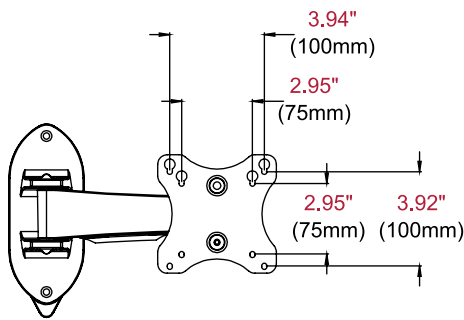

FRONT VIEW

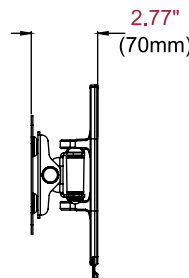

SIDE VIEW COLLAPSED

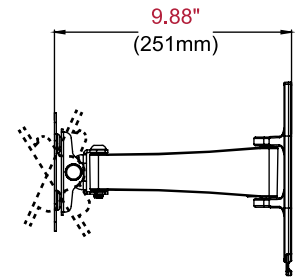

**SIDE VIEW EXTENDED
+/-35° TILT**

Architect Specifications

The Smartmount® Pivoting Wall Mount shall be a Peerless-AV model SP730P and shall be located where indicated on the plans. Assembly and installation shall be done according to instructions provided by the manufacturer.

Visit peerless-av.com to see the complete line of AV solutions from Peerless-AV, including outdoor displays, wireless, kiosks, digital audio, display mounts, projector mounts, carts/stands, and a full assortment of accessories.

Peerless-AV
2300 White Oak Circle
Aurora, IL 60502 USA
(800) 865-2112
(630) 375-5100
Fax: (800) 359-6500

Peerless-AV Europe
Unit 3 Watford Interchange
Colonial Way, Watford
Herts, WD24 4WP
United Kingdom
+44 (0) 1923 200100
Fax: +44 (0) 1923 200101

Peerless-AV de México
Ave de las Industrias 413
Parque Industrial Escobedo
Escobedo, N.L.,
Mexico 66050
+52 (81) 8384-8300
Fax: +52 (81) 8384-8360

