

ST640P	SmartMount® Universal Tilt Wall Mount for 32" to 50" Displays - standard models
ST640	SmartMount® Universal Tilt Wall Mount for 32" to 50" Displays - security models

Product Specifications

	DIMENSIONS (W x H x D)	PRODUCT WEIGHT	LOAD CAPACITY	FINISH	AVAILABLE COLORS
ST640(P)	22.14" x 16.89" x 2.62"-5.40" (562 x 429 x 67-137mm)	6.07lb (2.75kg)	150lb (68kg)	Scratch resistant fused epoxy	Semi-gloss black

Package Specifications

	PACKAGE SIZE (W x H x D)	PACKAGE SHIP WEIGHT	PACKAGE UPC CODE	PACKAGE CONTENTS	UNITS IN PACKAGE
ST640(P)	21.69" x 2.95" x 10.71" (551 x 75 x 272mm)	7.82lb (3.55kg)	ST640: 735029235699 ST640P: 735029235712	Wall mount, wall and display installation hardware, installation instructions	1

Accessories

ACC415: Metal Stud Fastener Kit

All dimensions = inch (mm)

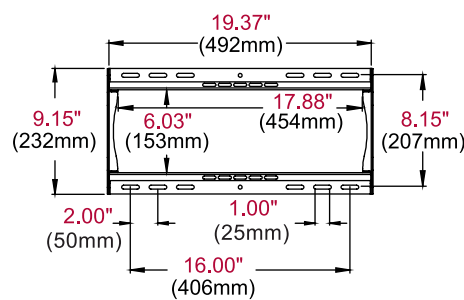

WALL PLATE

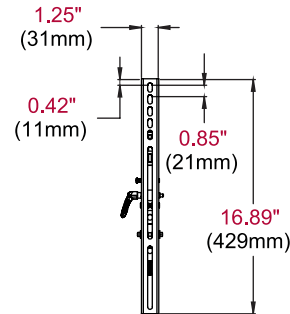

VERTICAL ADAPTOR

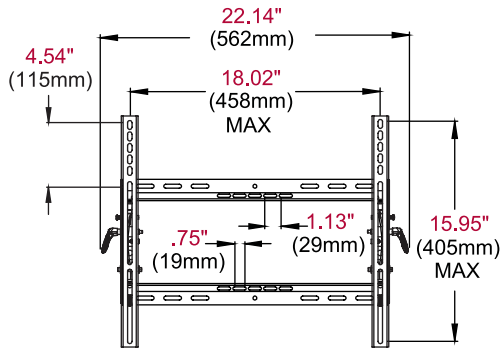

FRONT VIEW

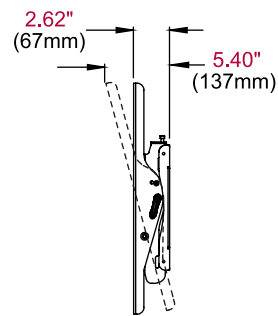

**SIDE VIEW
+15/-5° TILT**

Architect Specifications

The Smartmount® Tilt Wall Mount shall be a Peerless-AV model ST640(P) and shall be located where indicated on the plans. Assembly and installation shall be done according to instructions provided by the manufacturer.

Visit peerless-av.com to see the complete line of AV solutions from Peerless-AV, including outdoor displays, wireless, kiosks, digital audio, display mounts, projector mounts, carts/stands, and a full assortment of accessories.

Peerless-AV
2300 White Oak Circle
Aurora, IL 60502 USA
(800) 865-2112
(630) 375-5100
Fax: (800) 359-6500

Peerless-AV Europe
Unit 3 Watford Interchange
Colonial Way, Watford
Herts, WD24 4WP
United Kingdom
+44 (0) 1923 200100
Fax: +44 (0) 1923 200101

Peerless-AV de México
Ave de las Industrias 413
Parque Industrial Escobedo
Escobedo, N.L.,
Mexico 66050
+52 (81) 8384-8300
Fax: +52 (81) 8384-8360

