

Mounting instructions
 Montagevoorschrift
 Instructions de montage
 Montageanleitung
 Guía de montaje
 Istruzioni di montaggio
 Instruções de montagem
 Monteringsanvisning
 Instrukcja montażu
 Рекомендации по установке

PFF 7020

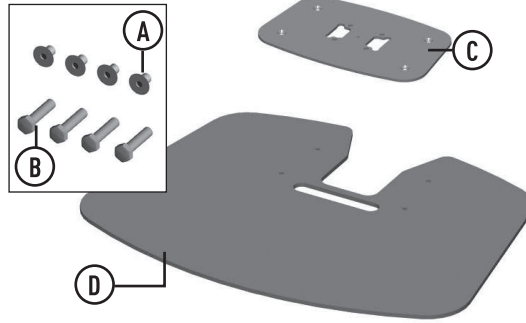

PFT 8520

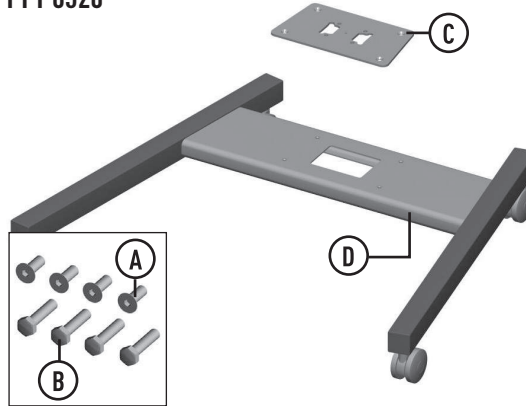

PFF 7040

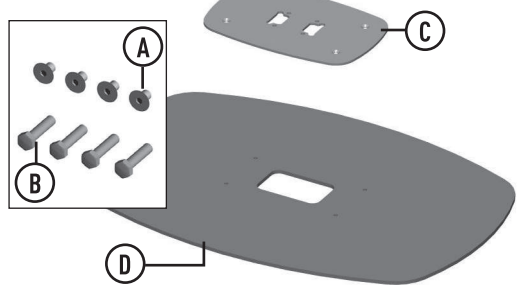

PFF 7060

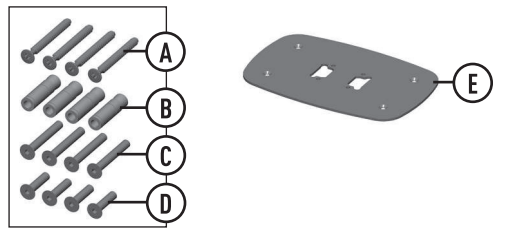

1 PFF 7020

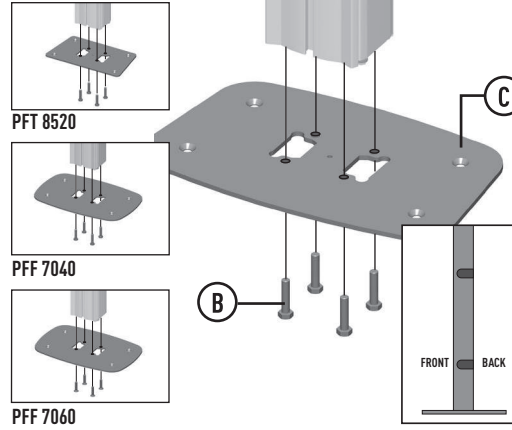

2 PFF 7020

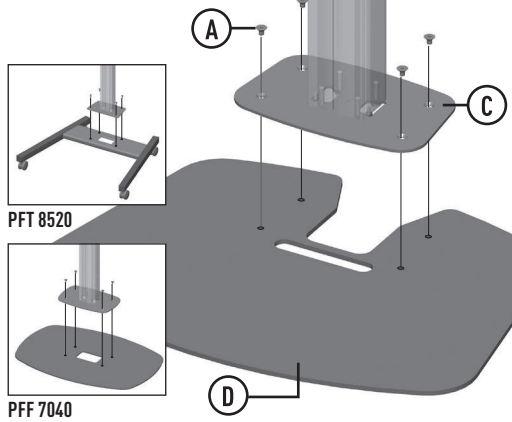

2a PFF 7060

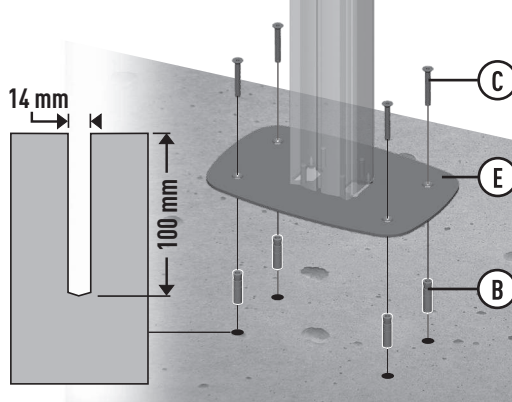

2b PFF 7060

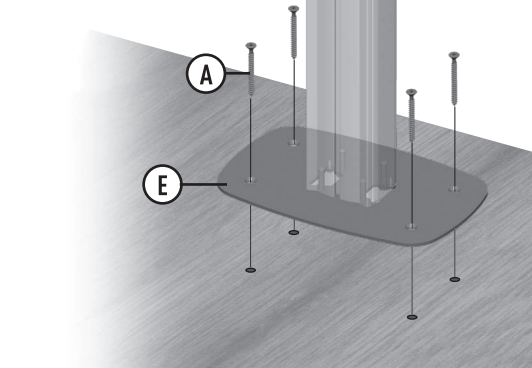

3

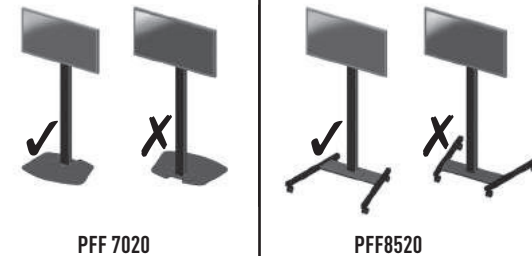
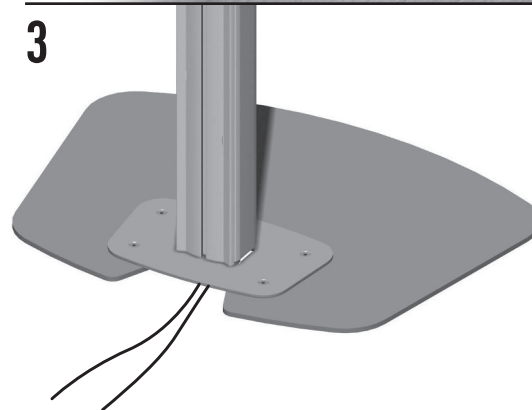

(GB) Subject to printing errors and technical amendments.
 (NL) Drukfouten en technische wijzigingen voorbehouden.
 (F) Sous réserve de fautes d'impression et de modifications techniques.
 (D) Für Druckfehler übernehmen wir keine Verantwortung. Technische Änderungen vorbehalten.
 (E) Reservados errores de imprenta y sujeta a modificaciones.
 (I) Con riserva di modifiche tecniche e di eventuali errori di stampa.
 (P) Reserva-se a ocorrência de galhas e de modificações técnicas.
 (H) Nyomdahibák és technikai változtatások joga fenntartva.
 (PL) Zastrzega się możliwość występowania błędów drukarskich i zmian technicznych.
 (RUS) Возможны ошибки при печати и технические модификации.



PUC 2715
PUC 2718
PUC 2720

Pole connect-it XL

Mounting instructions
Montagevoorschrift
Instructions de montage
Montageanleitung
Guía de montaje
Istruzioni di montaggio
Instruções de montagem
Monteringsanvisning
Instrukcja montażu
Рекомендации по установке

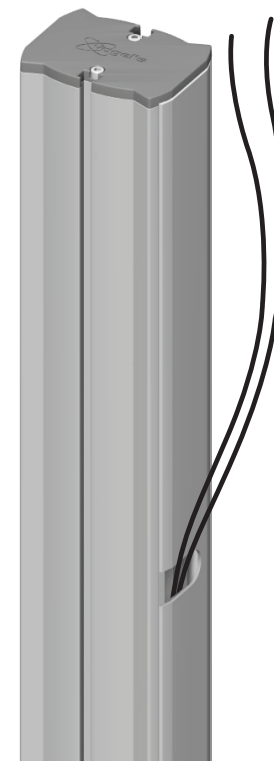
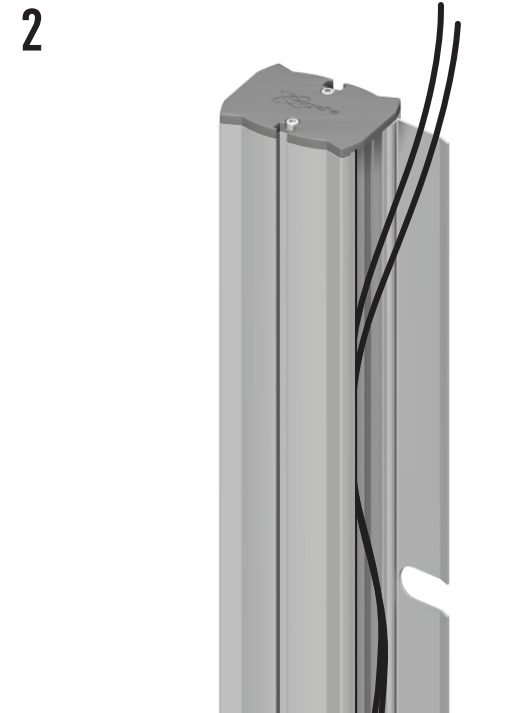
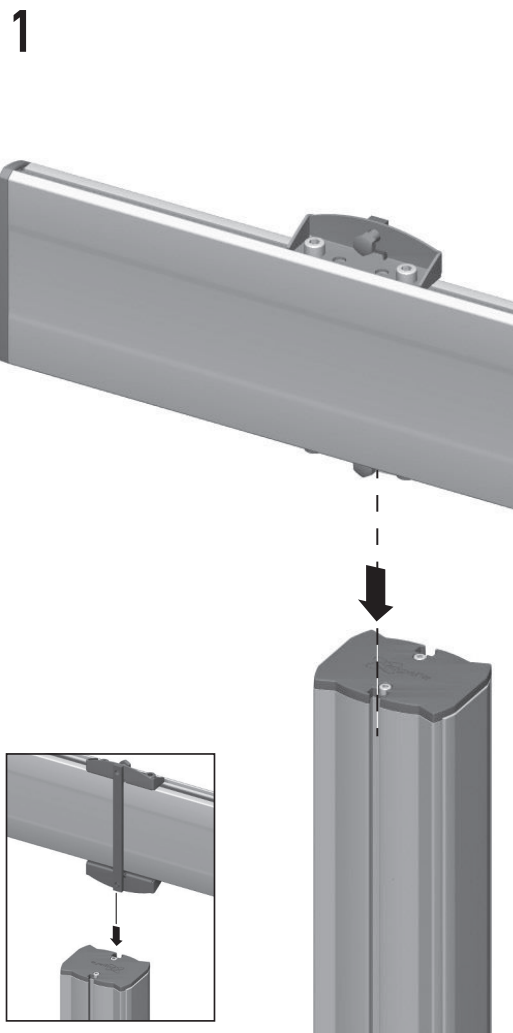
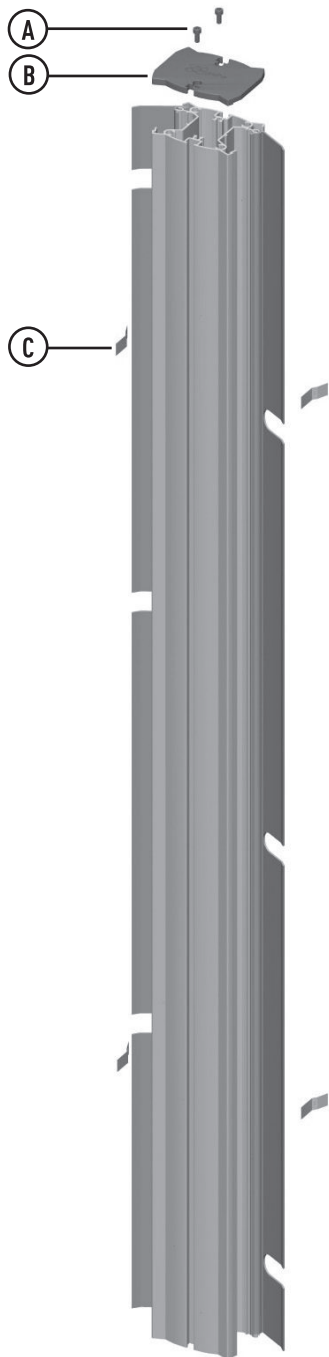

(GB) Subject to printing errors and technical amendments.
(NL) Drukfouten en technische wijzigingen voorbehouden.
(F) Sous réserve de fautes d'impression et de modifications techniques.
(D) Für Druckfehler übernehmen wir keine Verantwortung. Technische Änderungen vorbehalten.
(E) Reservados errores de imprenta y sujeta a modificaciones.
(I) Con riserva di modifiche tecniche e di eventuali errori di stampa.
(P) Reserva-se a ocorrência de galhas e de modificações técnicas.
(H) Nyomdahibák és technikai változtatások joga fenntartva.
(PL) Zastrzega się możliwość występowania błędów drukarskich i zmian technicznych.
(RUS) Возможны ошибки при печати и технические модификации.



Interface bar

- | | |
|----------|----------|
| PFB 3402 | PFB 3411 |
| PFB 3405 | PFB 3419 |
| PFB 3407 | PFB 3427 |
| PFB 3409 | PFB 3433 |

- Mounting instructions
 Montagevoorschrift
 Instructions de montage
 Montageanleitung
 Guía de montaje
 Istruzioni di montaggio
 Instruções de montagem
 Monteringsanvisning
 Instrukcja montażu
 Рекомендации по установке

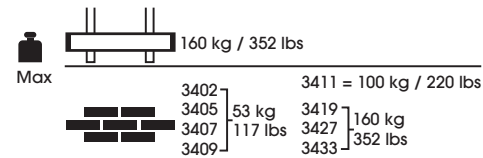

PFB 3402
 PFB 3405
 PFB 3407
 PFB 3409

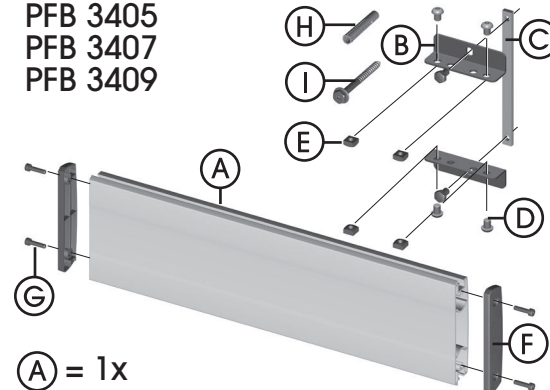

- (A) = 1x
 (B) = 2x (C) = 1x (D) = 4x (E) = 4x
 (F) = 2x (G) = 4x (H) = 2x (I) = 2x

PFB 3411

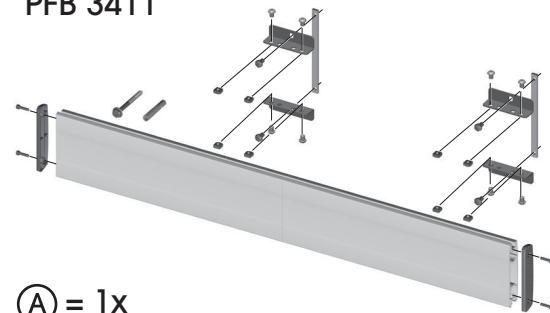

- (A) = 1x
 (B) = 4x (C) = 2x (D) = 8x (E) = 8x
 (F) = 2x (G) = 4x (H) = 4x (I) = 4x

PFB 3419
 PFB 3427
 PFB 3433

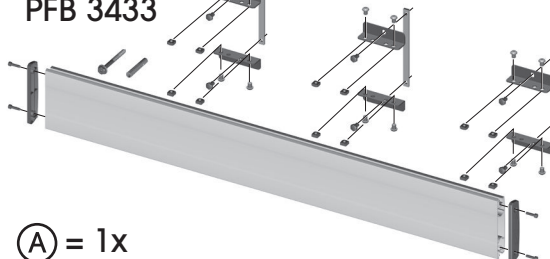

- (A) = 1x
 (B) = 6x (C) = 3x (D) = 12x (E) = 12x
 (F) = 2x (G) = 4x (H) = 6x (I) = 6x

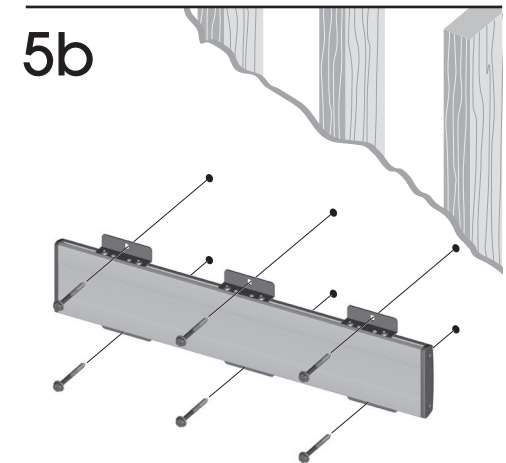
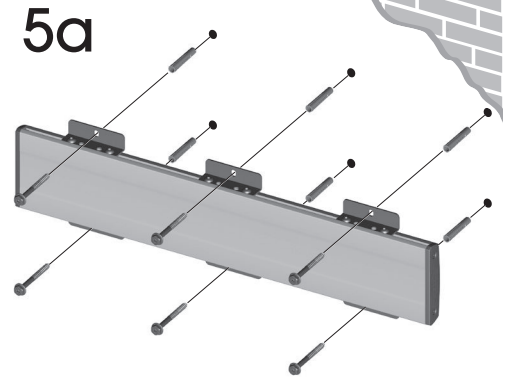
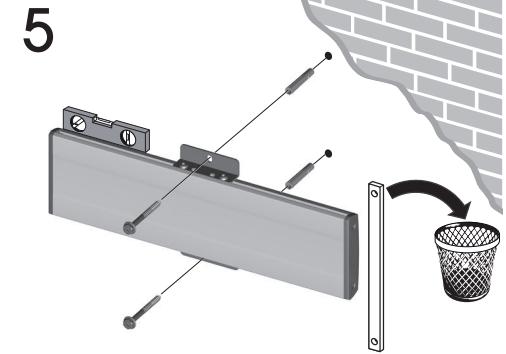
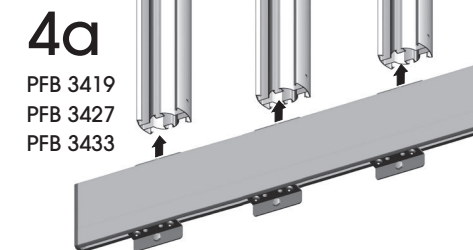
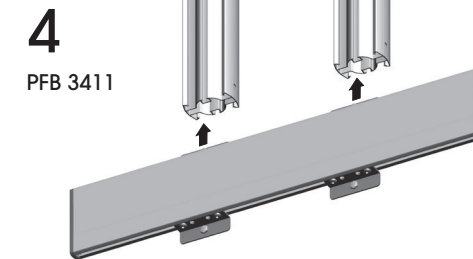
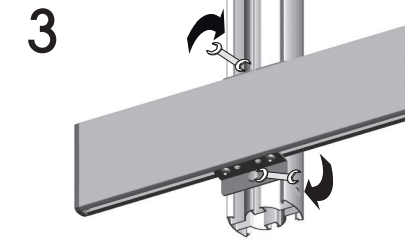
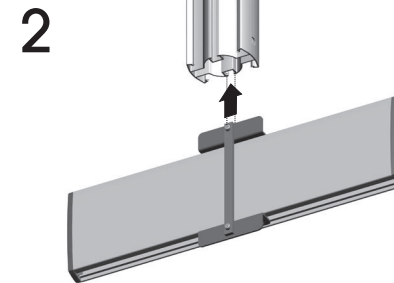
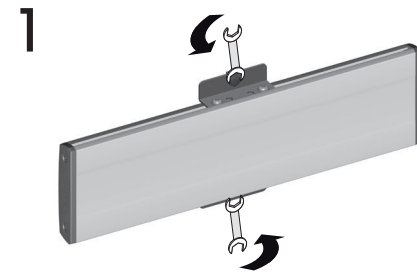

(GB) Subject to printing errors and technical amendments.
 (NL) Drukfouten en technische wijzigingen voorbehouden.
 (F) Sous réserve de fautes d'impression et de modifications techniques.
 (D) Für Druckfehler übernehmen wir keine Verantwortung. Technische Änderungen vorbehalten.
 (E) Reservados errores de imprenta y sujeta a modificaciones.
 (I) Con riserva di modifiche tecniche e di eventuali errori di stampa.
 (P) Reserva-se a ocorrência de gralhas e de modificações técnicas.
 (H) Nyomdahibák és technikai változtatások joga fenntartva.
 (PL) Zastrzeżenie możliwości występowania błędów drukarskich i zmian technicznych.
 (RUS) Возможны ошибки при печати и технические модификации.

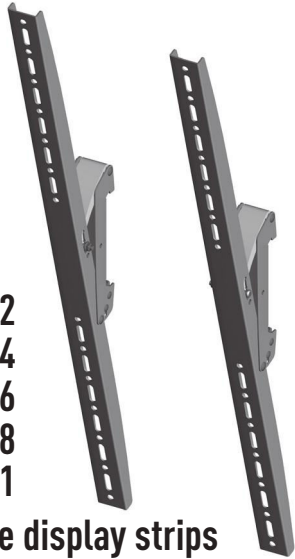

PFS 3302
PFS 3304
PFS 3306
PFS 3308
PFS 3311

Interface display strips

Mounting instructions
Montagevoorschrift
Instructions de montage
Montageanleitung
Guía de montaje
Istruzioni di montaggio
Instruções de montagem
Monteringsanvisning
Instrukcja montażu
Рекомендации по установке

Max. (2x) 80 kg / (2x) 176 lbs

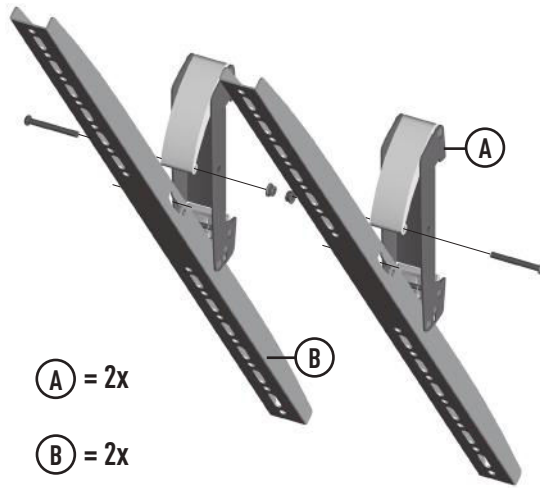

(A) = 2x

(B) = 2x

(C) 4x

(D) 4x

(E) 4x

(F) 4x

(G) 4x

(H) 4x

(I) 4x

(J) 8x

(K) 8x

(GB) Subject to printing errors and technical amendments.
(NL) Drukfouten en technische wijzigingen voorbehouden.
(F) Sous réserve de fautes d'impression et de modifications techniques.
(D) Für Druckfehler übernehmen wir keine Verantwortung. Technische Änderungen vorbehalten.
(E) Reservados errores de imprenta y sujeta a modificaciones.
(I) Con riserva di modifiche tecniche e di eventuali errori di stampa.
(P) Reserva-se a ocorrência de galhas e de modificações técnicas.
(H) Nyomdahibák és technikai változtatások joga fenntartva.
(PL) Zastrzega się możliwość występowania błędów drukarskich i zmian technicznych.
(RUS) Возможны ошибки при печати и технические модификации.

