

User's Guide
Guía del usuario
Manuel de l'utilisateur
Benutzerhandbuch
Gebruikersgids
Gebruikersgids
Guida per l'utente
Användarguide
ユーザーガイド
用户指南
사용자 안내서



CAUTION!
MAXIMUM WEIGHT CAPACITY



CAUTION!
MAXIMUM SCREEN SIZE

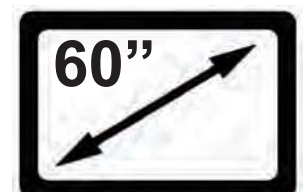

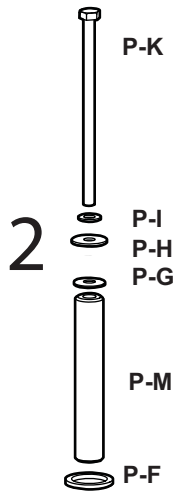

CONTENTS

Part	Quantity	Description
1	1	Wall Plate
2	1	Arm/Wall Plate Hardware
3	2	Wall Plate Covers
4	1	Rear Arm Cover
5	1	CFT Arm
6	1	200x200 VESA Monitor Plate
7	4	Spider Adapters

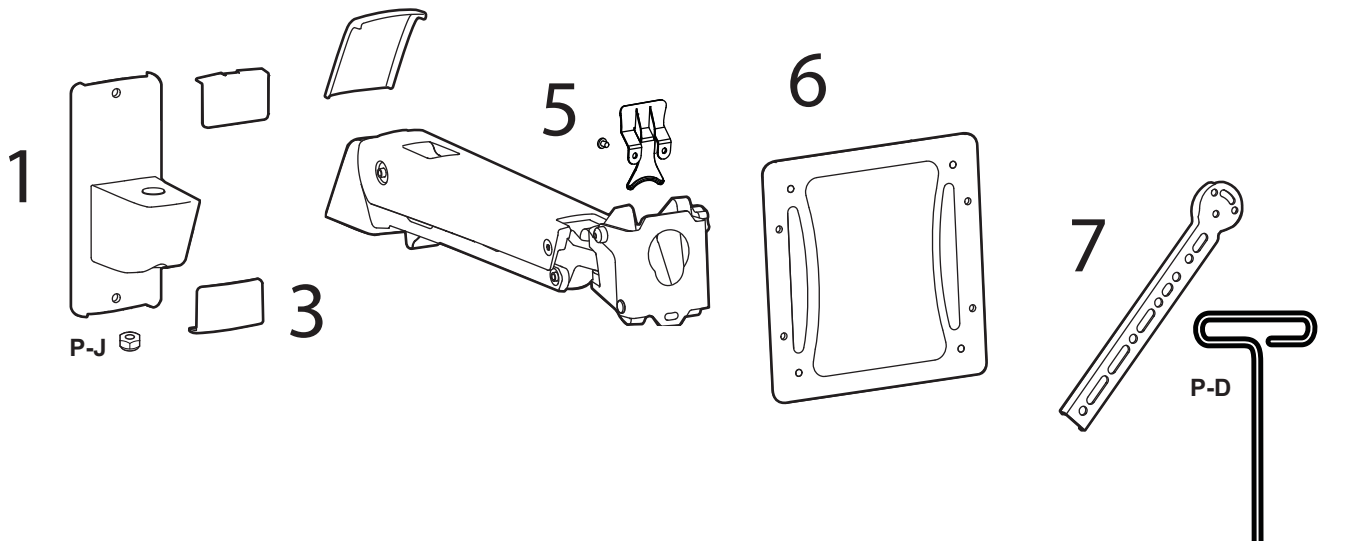

Screws/Hardware For Flat Panel 697-613-00

Part	Quantity	Description
M-A	4	Philips screws M4 x 15mm
M-B	4	Philips screws M4 x 30mm
M-C	4	Philips screws M5 x 15mm
M-D	4	Philips screws M5 x 30mm
M-E	4	Philips screws M6 x 15mm
M-F	4	Philips screws M6 x 30mm
M-G	4	Philips screws M8 x 15mm
M-H	4	Philips screws M8 x 30mm
M-I	4	Round spacers M6-M8 x 5mm
M-J	4	Round spacers M6-M8 x 10mm
M-K	4	Round washers M4-M5
M-L	4	Round washers M6-M8

Wall Kit ST8x2 697-641-00

Part	Quantity	Description
W-A	2	Lag Bolt
W-B	2	Round Washers
W-C	2	Wall Anchor

Specialty Hardware kit 697-640-00

Part	Quantity	Description
P-A	1	Philips Screw
P-B	4	Round Head Screws
P-C	8	Nuts

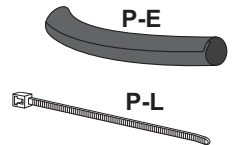
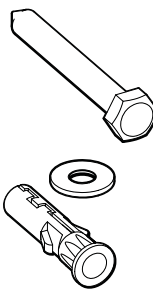

TOOLS NEEDED

Tools Needed

Herramientas necesarias
 Outils requis
 Benötigte Werkzeuge
 Benodigde gereedschappen
 Strumenti necessari
 Potrzebne narzędzia
 Potřebné nástroje
 Szükséges eszközök
 Απαιτούμενα εργαλεία
 Ferramentas necessàrias
 Nødvendigt værktøj
 Tarvittavat työkalut
 Verktøy som krævs
 Instrumente necesare
 Необходими уреди
 Vajalikud tööriistad
 Nepieciešamie rīki
 Reikalingi įrankiai
 Potrebno orodje
 Potrebne náradie
 Необходимые инструменты
 Gereklí Aletler
 Nødvendige verktøy
 كتر اليا تار دالا
 需要的工具
 必要なツール

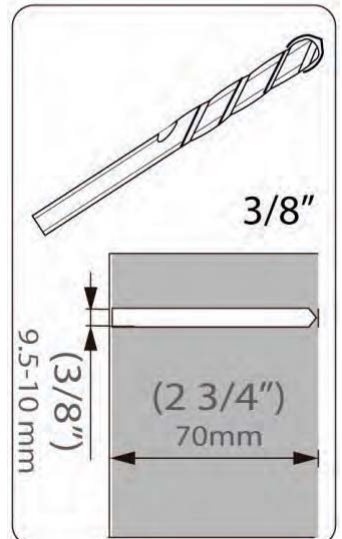
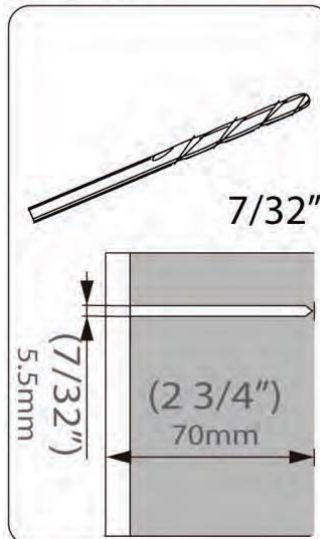
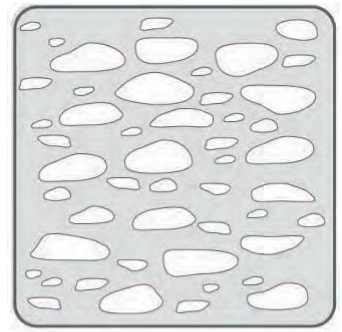
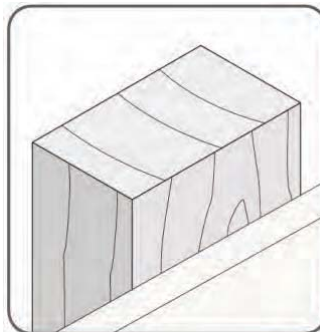
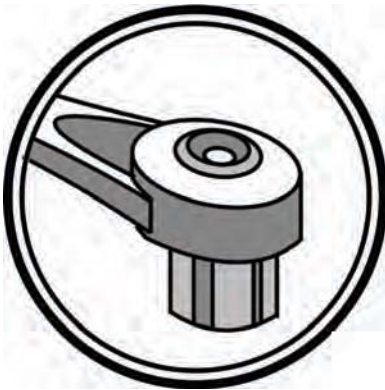
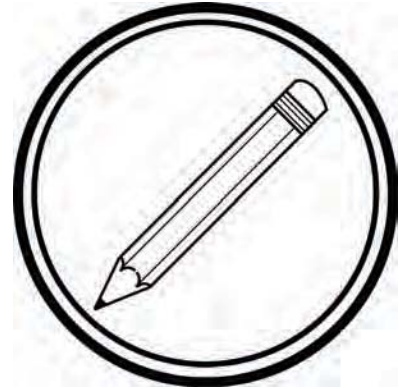
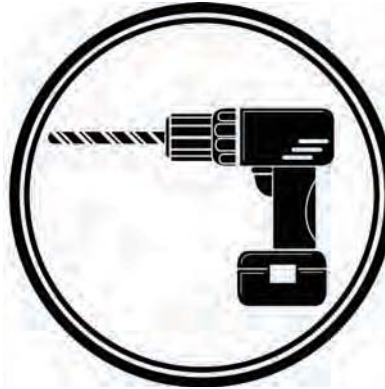
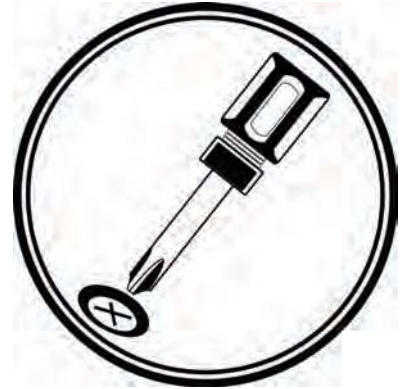
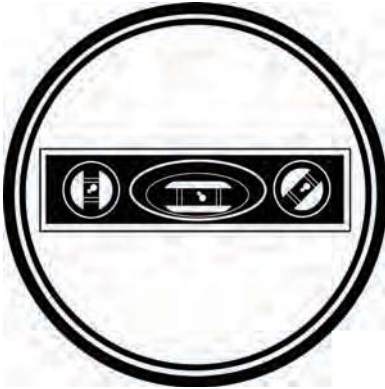

Wood Stud Mount

1 a

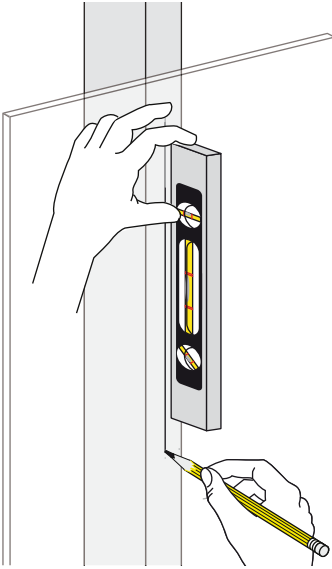

b

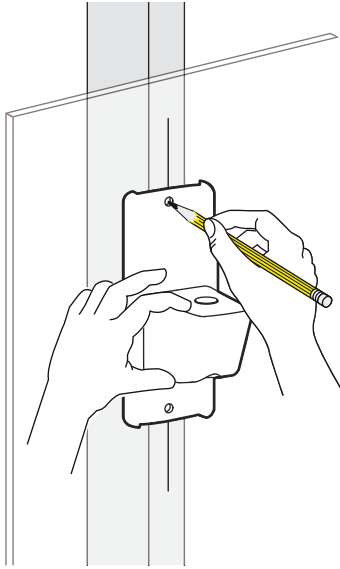

c

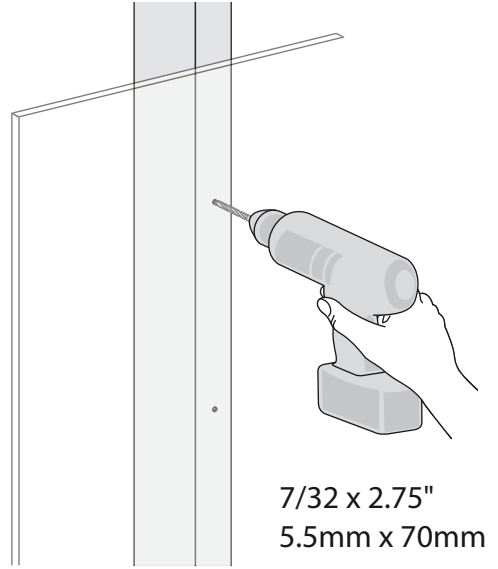

2 a

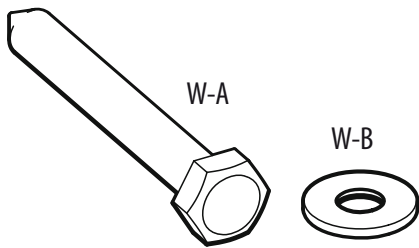

b

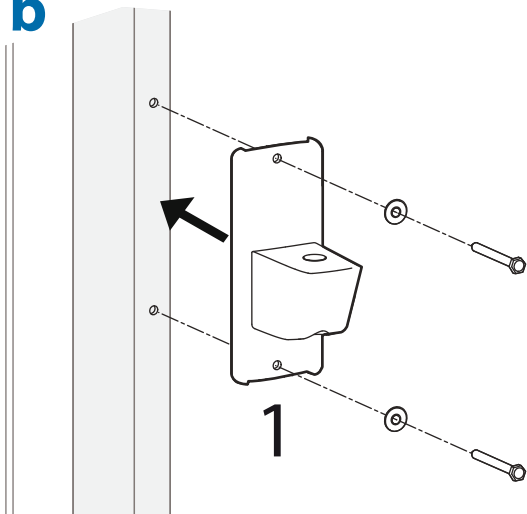

c

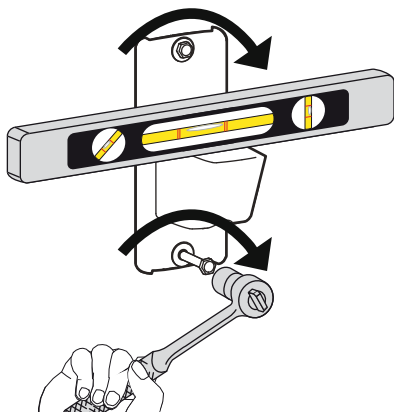

d

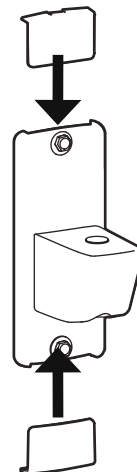

1 a

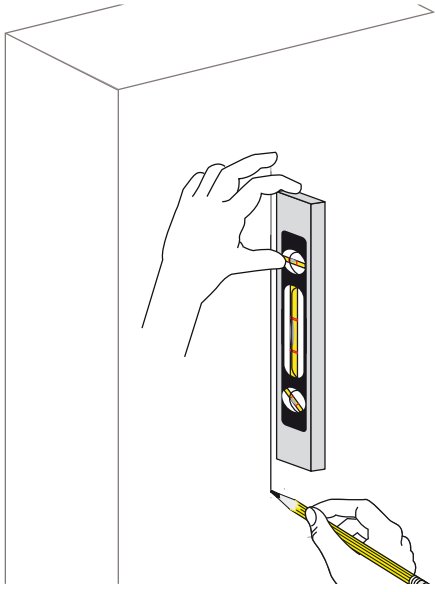

b

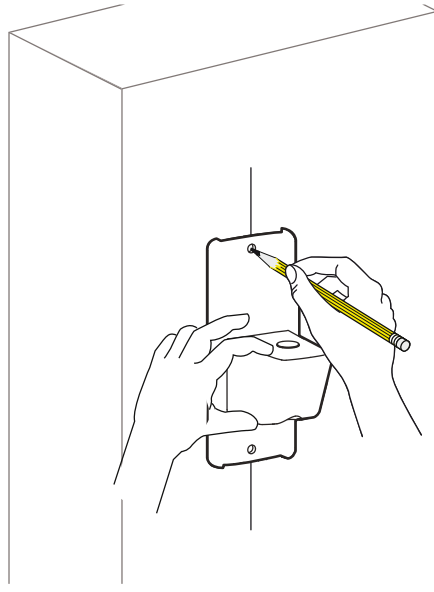

c

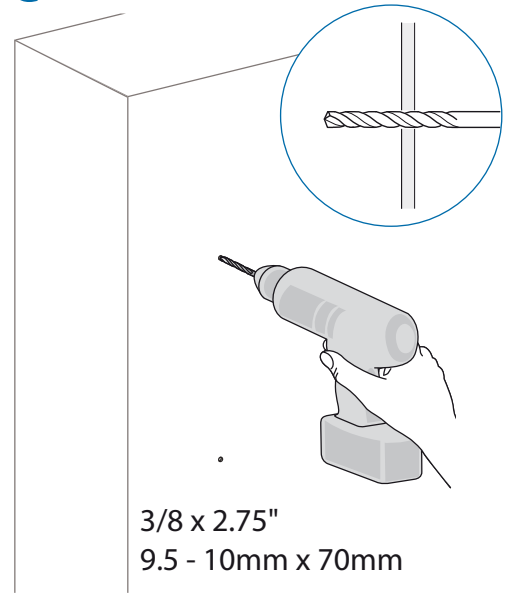

2 a

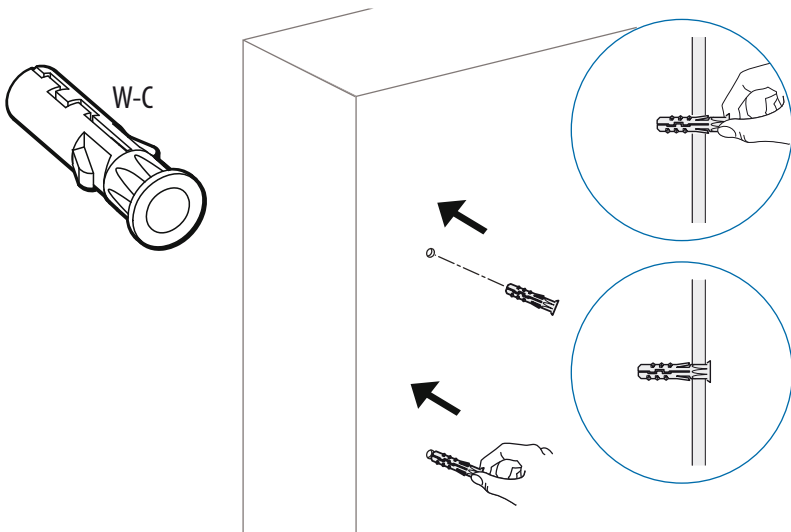

b

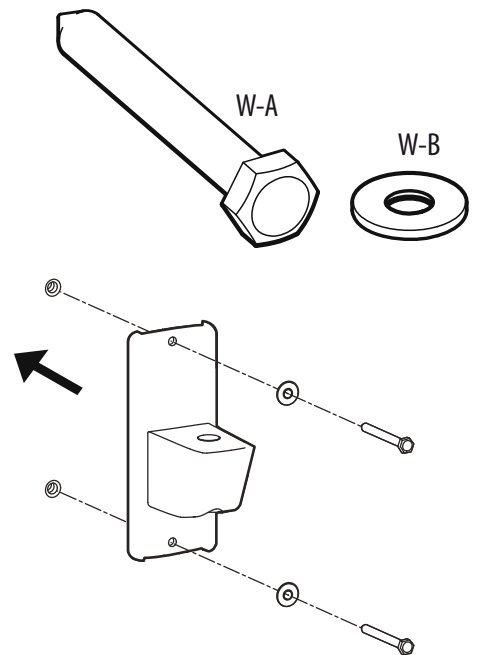

c

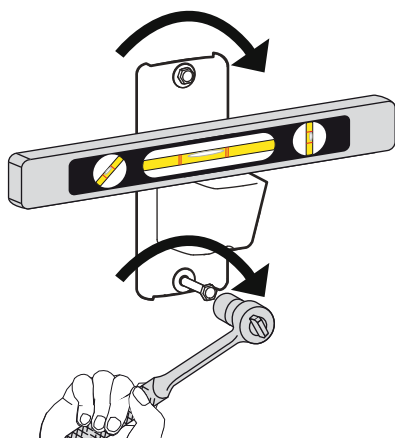

d

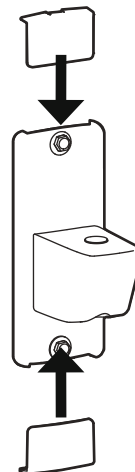

Wall Track Mount (Optional Accessory - Not Included)

1

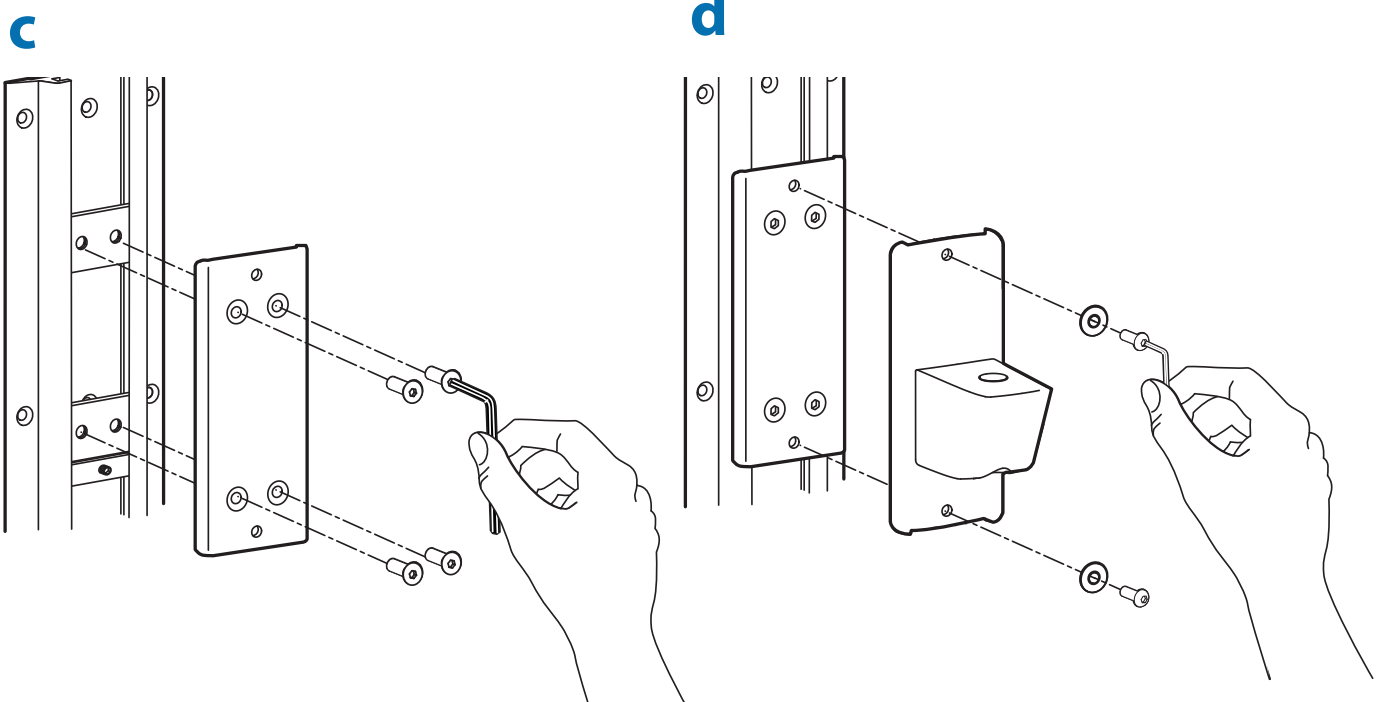
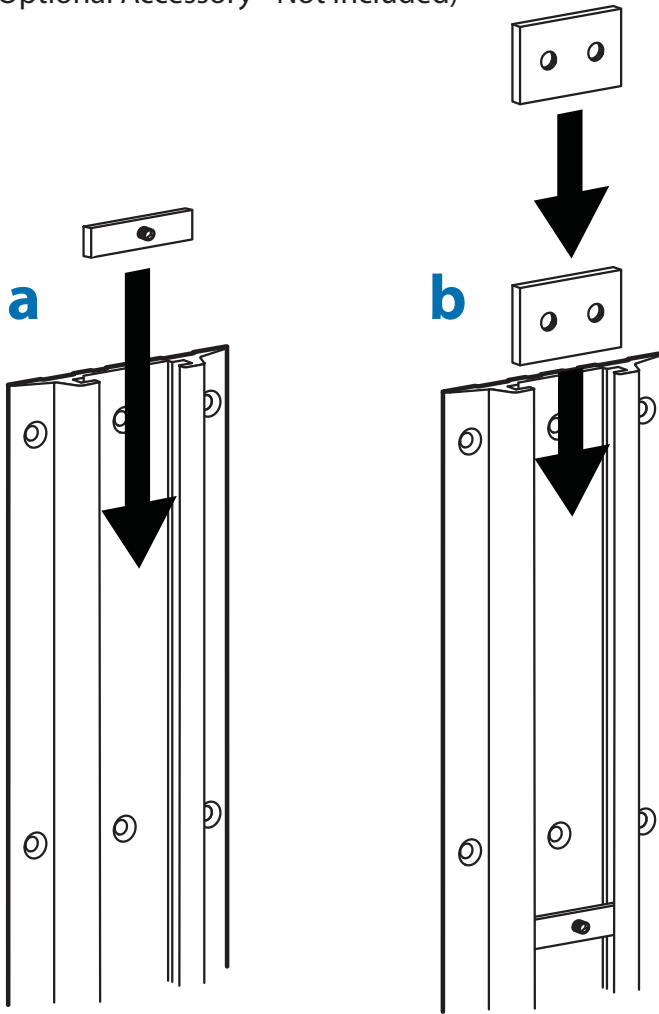

3 a

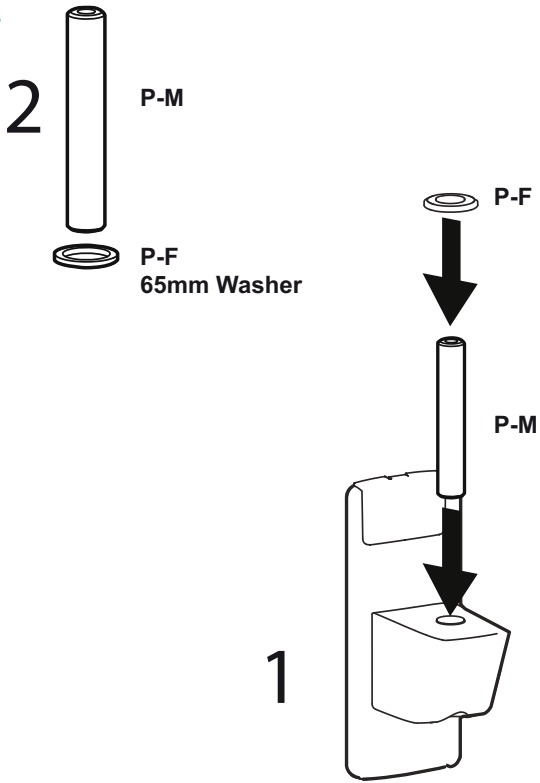

b

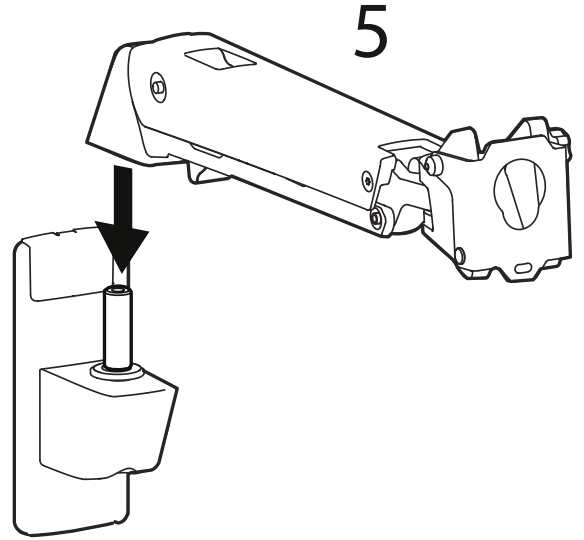

c

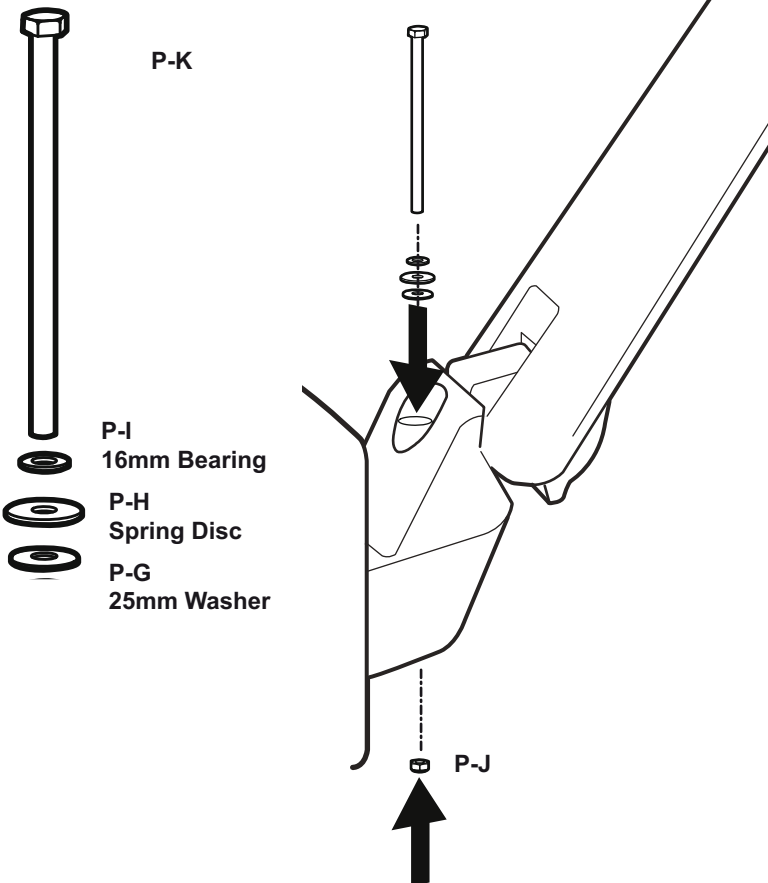

d

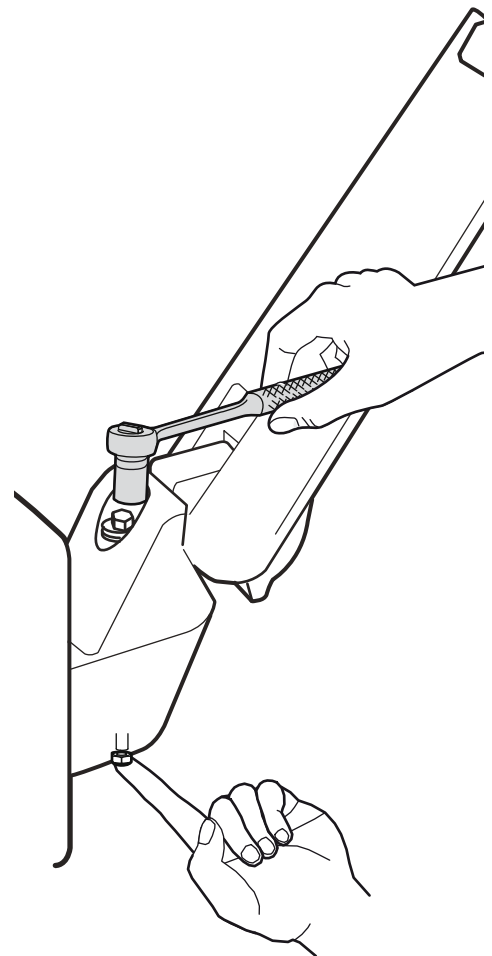

4

A

100 x 200
200 x 200

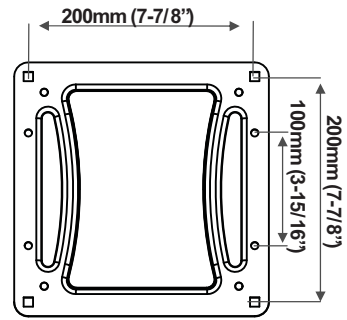
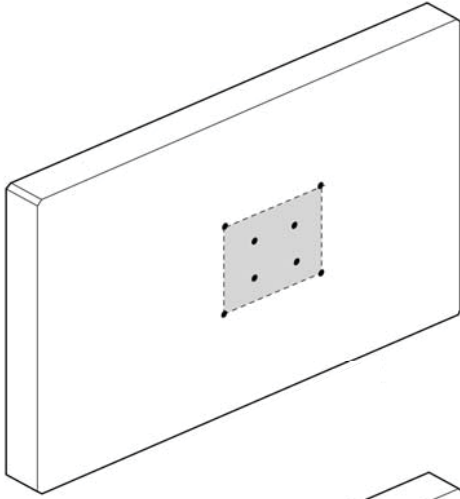

B

200 x 300
200 x 400

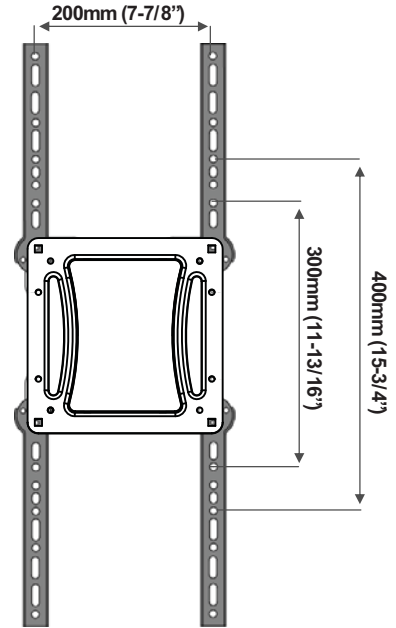
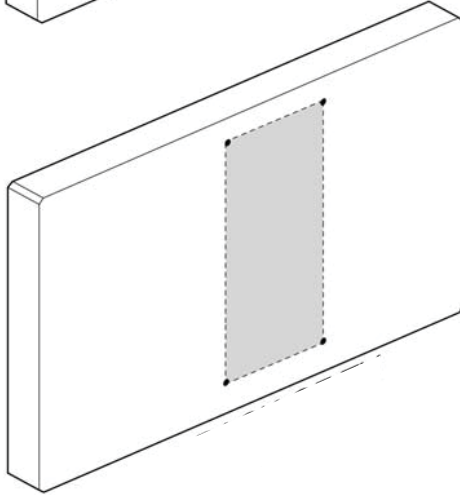

C

300 x 300
300 x 400
400 x 400
600 x 400

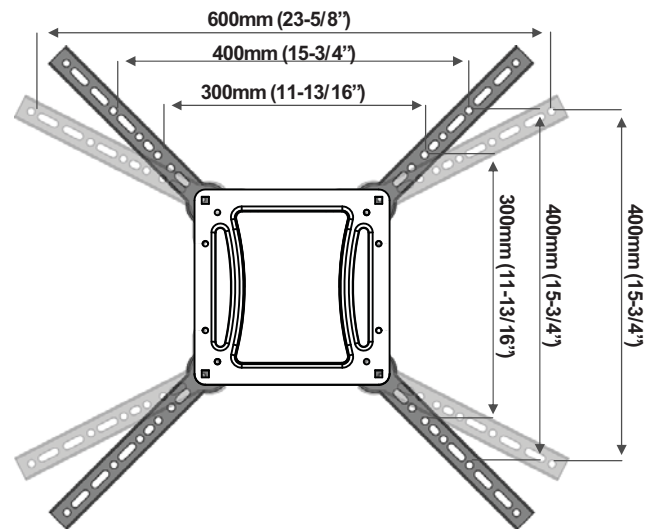
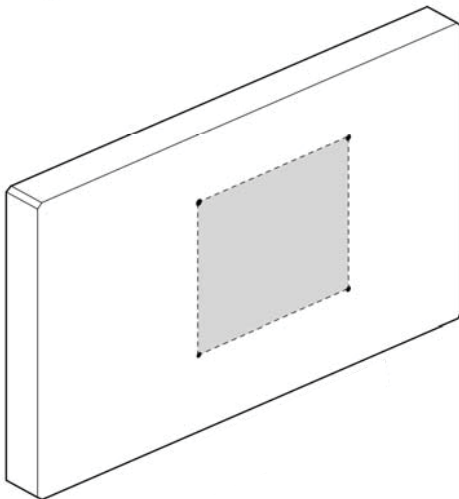

D

300 x 200
400 x 200

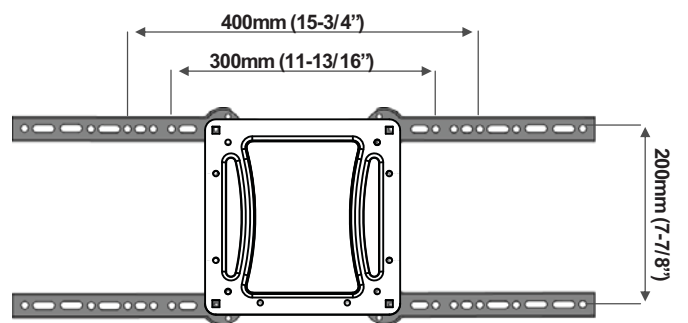
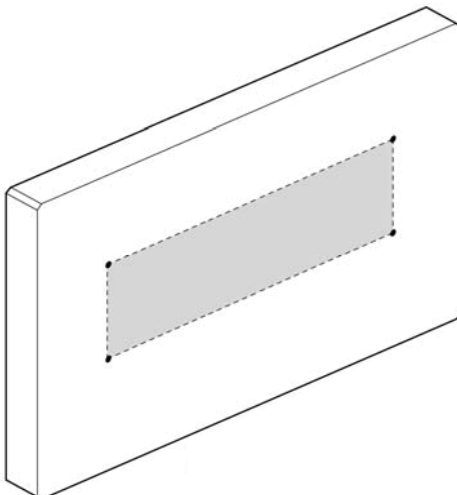

A

100 x 200
200 x 200

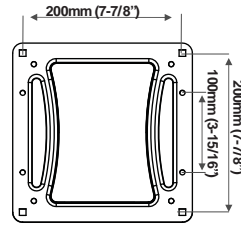
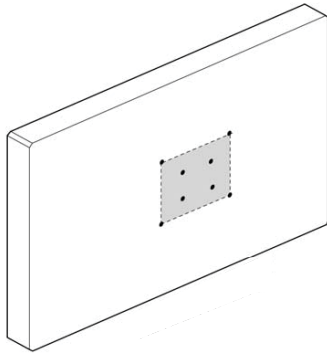

A E A E S E E O A A E S E E O A A E
A E O E O A A E S E A E

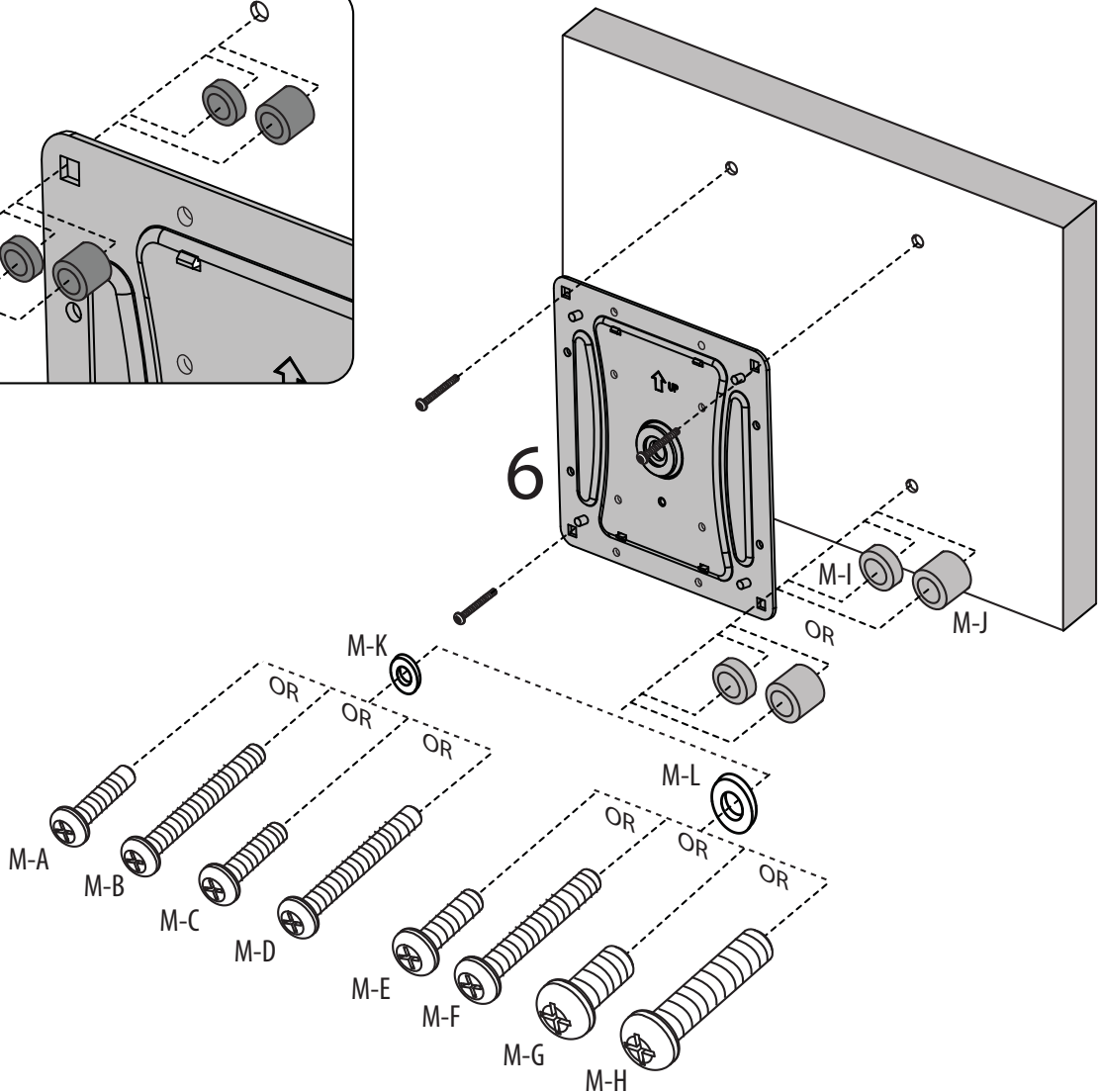
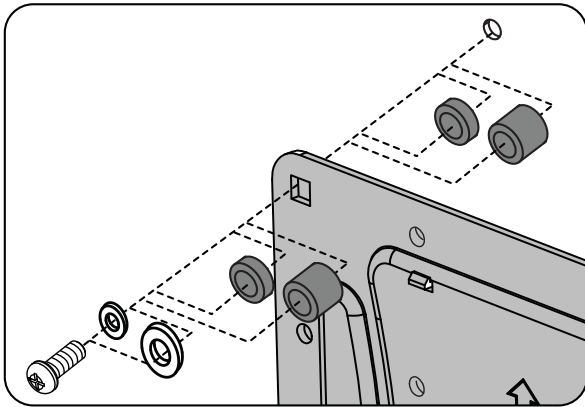
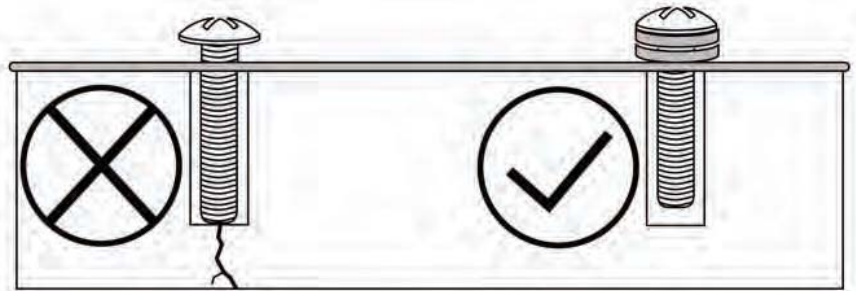
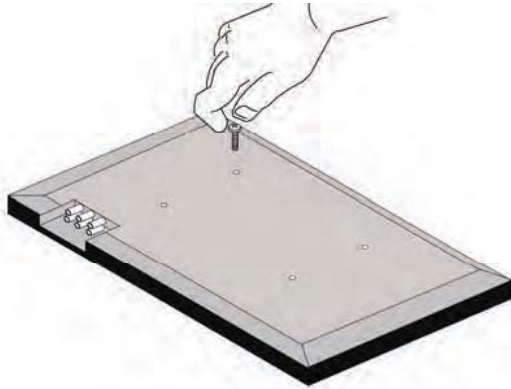

B

200 x 300
200 x 400

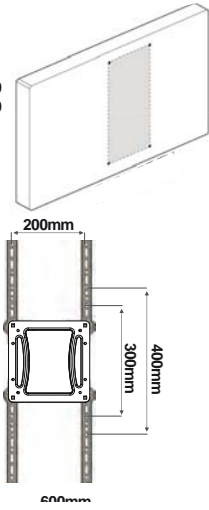

C

300 x 300
300 x 400
400 x 400
600 x 400

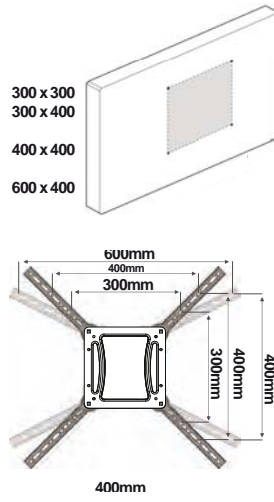

D

300 x 200
400 x 200

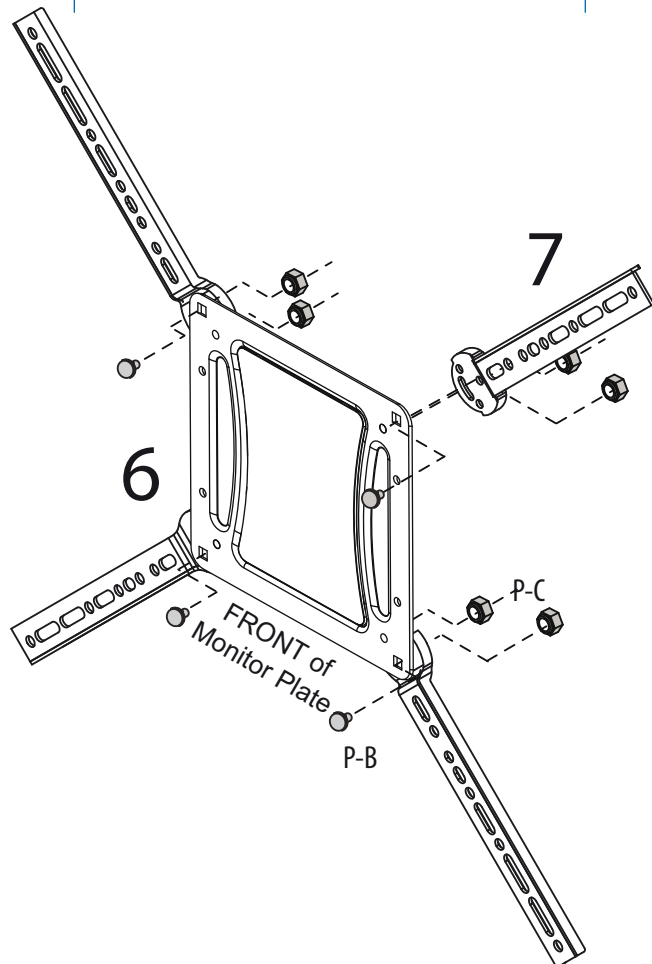
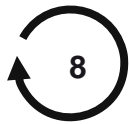
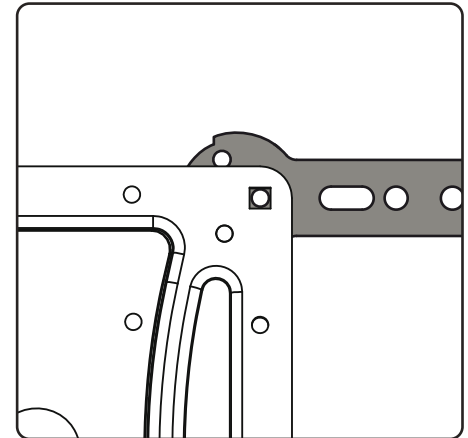
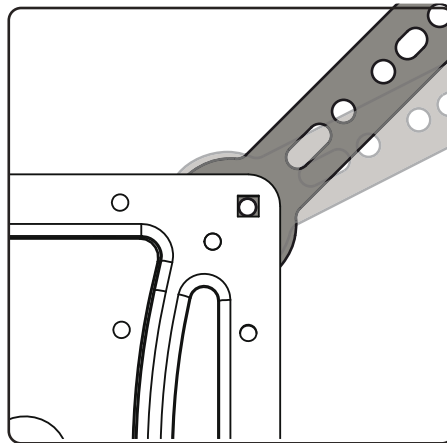
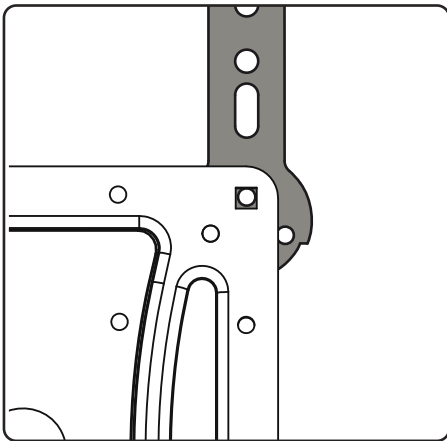
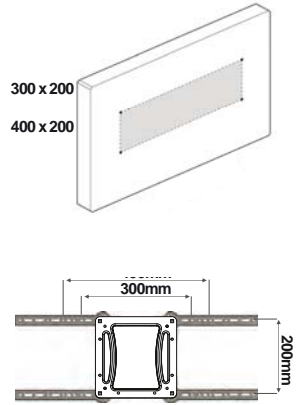

B / C / D

NING P S S CTT P OP SC NGT O OU TP N
 B NDTIG T NINGTOC C OU TP N ST DD PT

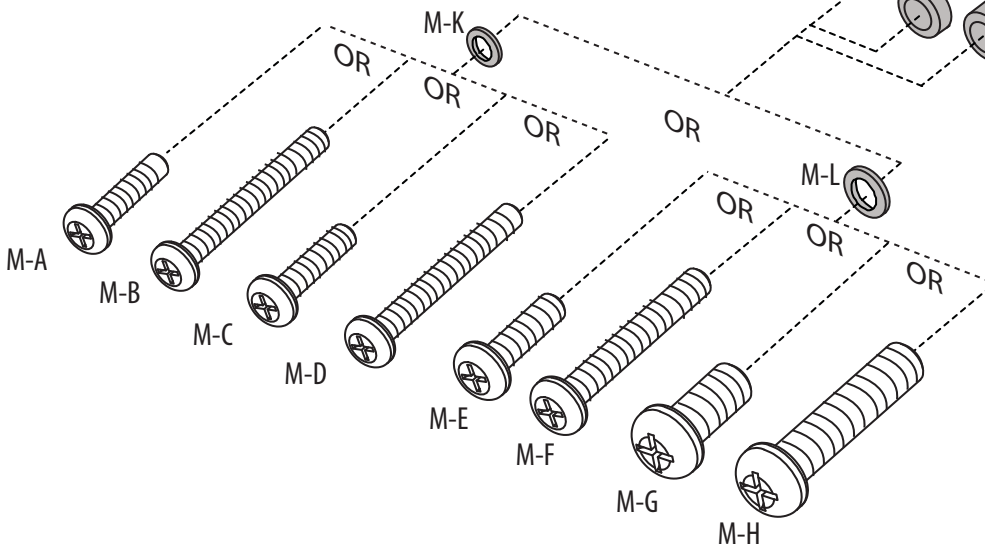
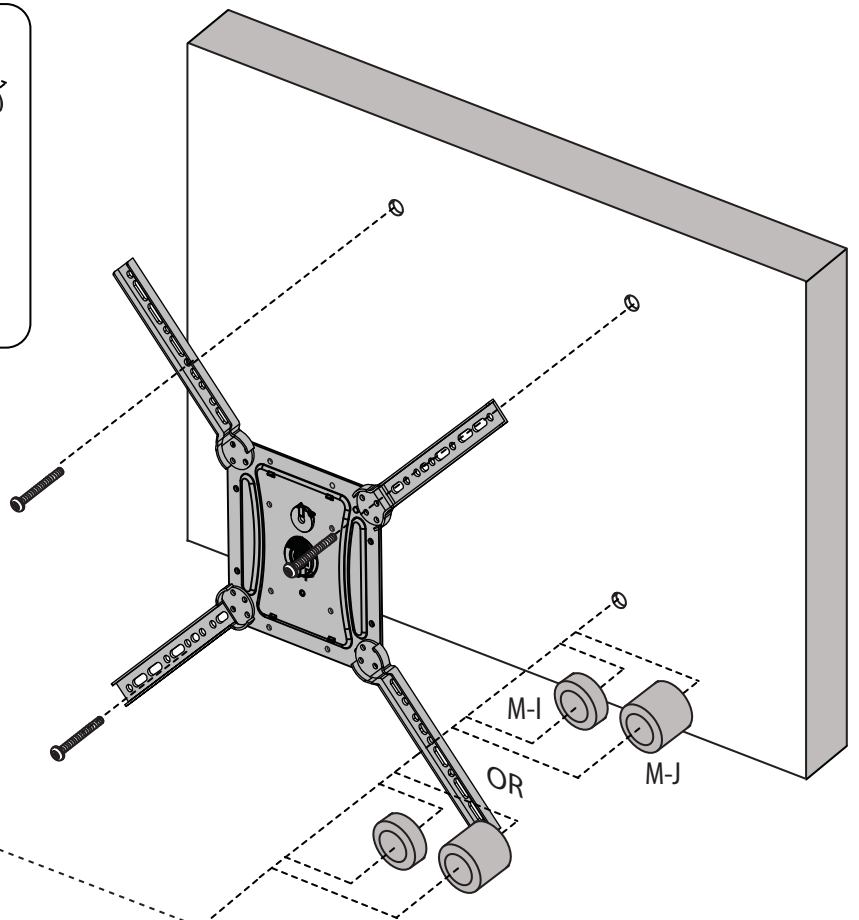
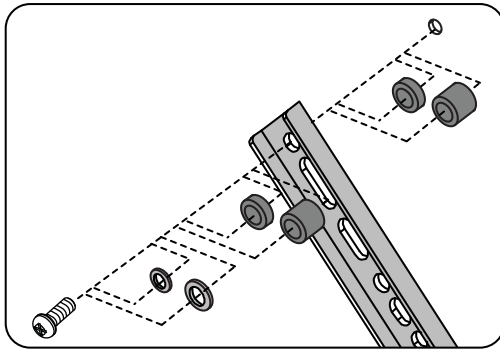
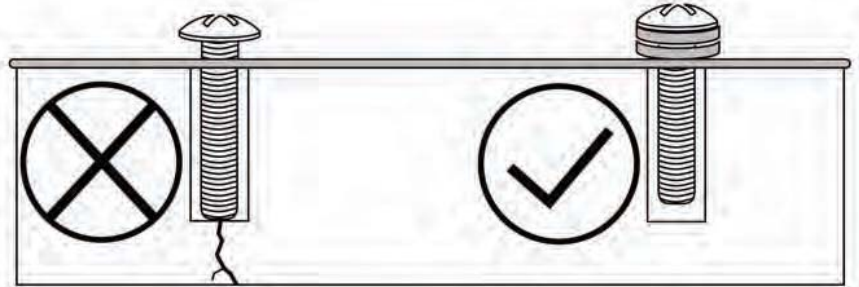
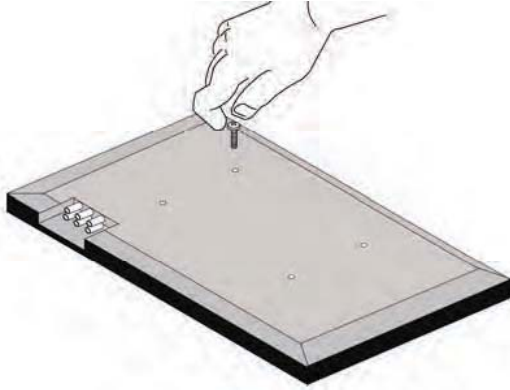

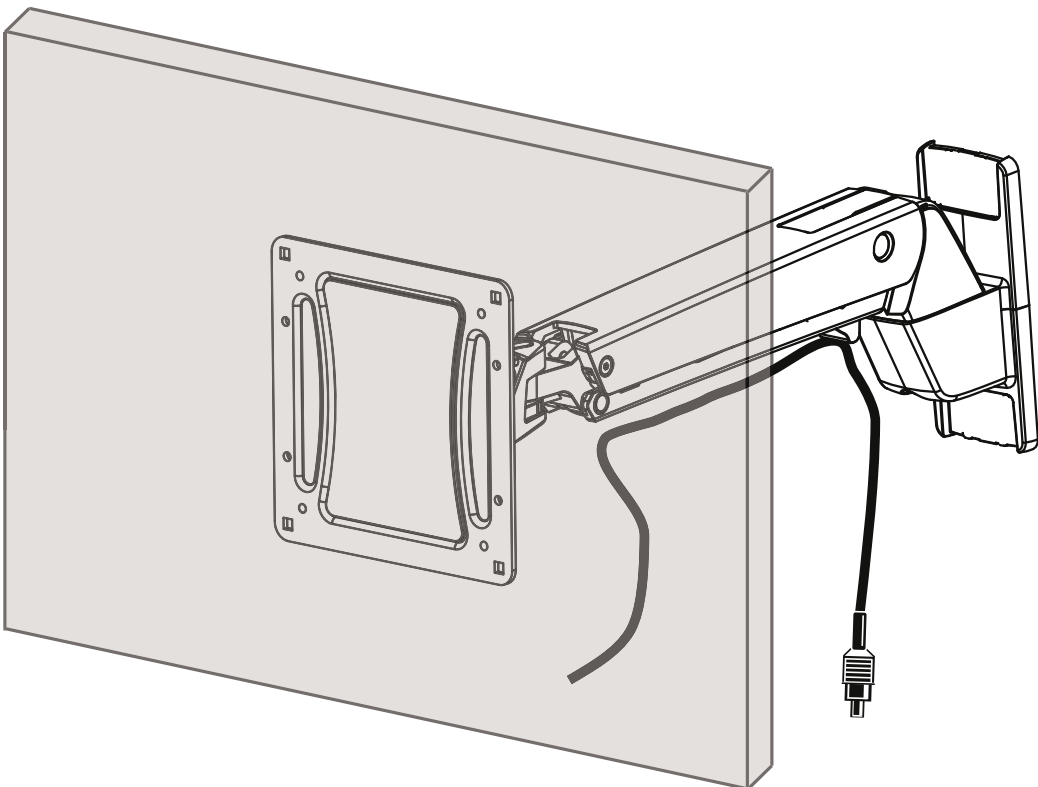
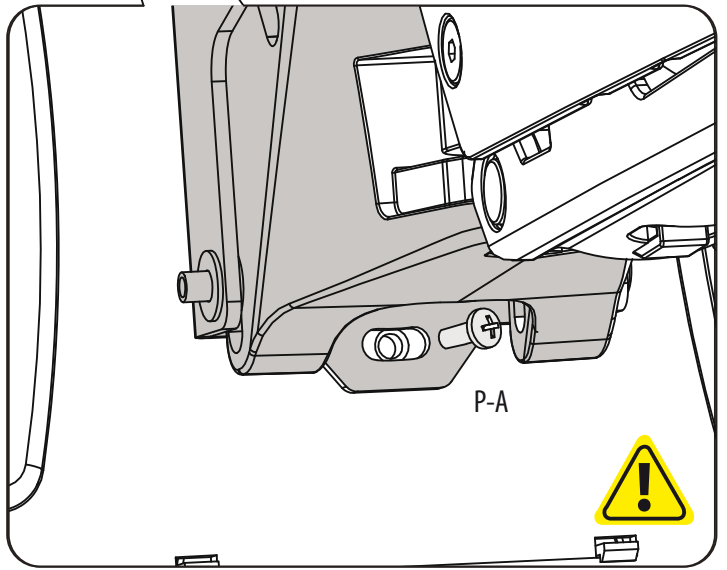
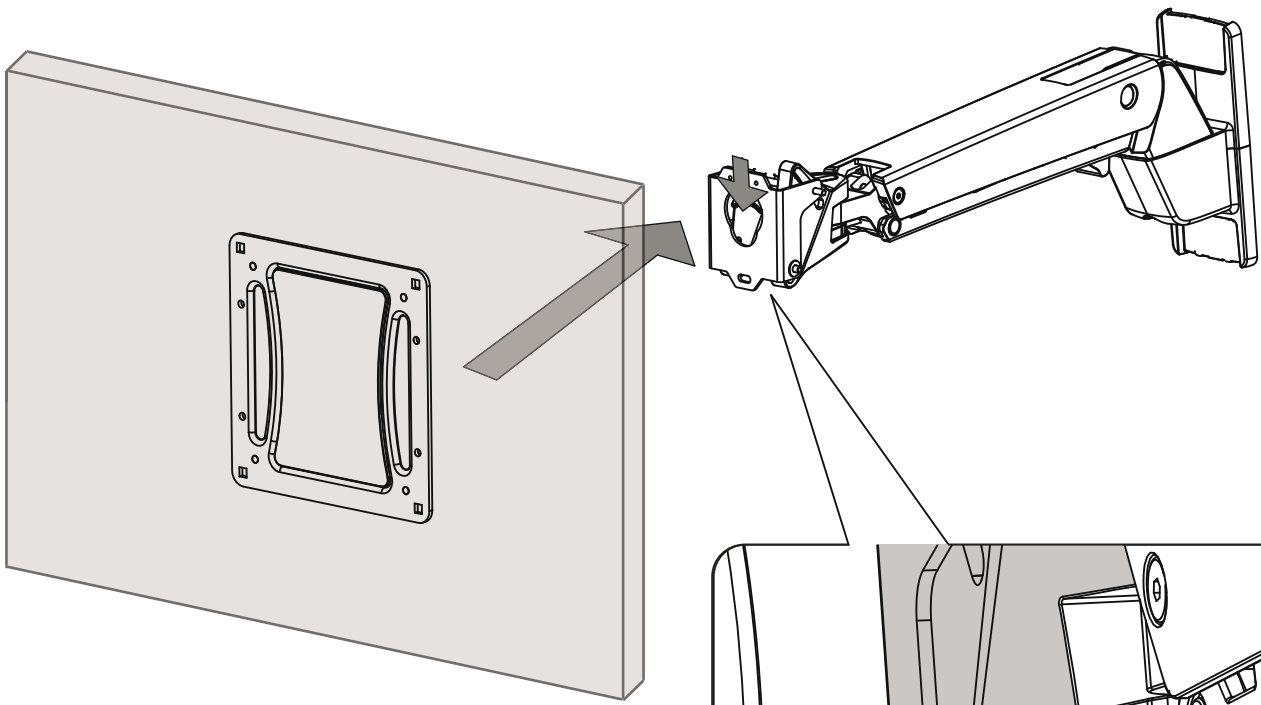

P-E



P-L



It is important that you adjust this product according to the weight of the mounted equipment as described in the following steps. Any time equipment is added or removed from this product, resulting in a change in the weight of the mounted load, you should repeat these adjustment steps to ensure safe and optimum operation. • Adjustments should move smoothly and easily through the full range of motion and stay where you set it. If adjustments are difficult and do not stay in the desired position, follow the instructions to loosen or tighten the tension to create a smooth, easy adjustment motion. Depending on your product and the adjustment, it may take several turns to notice a difference.

Es importante ajustar este producto conforme al peso del equipo montado, según se describe en los pasos siguientes. Cada vez que se agregue o quite equipo de este producto y cambie el peso de la carga montada, deberá repetir estos ajustes para garantizar un funcionamiento seguro y óptimo. • Los movimientos de ajuste deben poder realizarse de manera suave y firme dentro de la amplitud de movimiento permitida, y mantenerse donde usted los fije. Si los ajustes son abruptos o no permanecen en dicha posición, siga las instrucciones para aflojar o ajustar la tensión y suavizar así el movimiento. Dependiendo del producto y el ajuste, es posible que deba hacer varios intentos hasta poder observar la diferencia.

Il est important que vous fixiez ce produit par rapport au poids du matériel installé, comme l'indiquent les étapes suivantes. À chaque fois que vous ajoutez ou que vous retirez du matériel de ce produit, et que le poids du matériel change, répétez ces étapes d'ajustement pour garantir la sécurité et une utilisation optimale. • Les réglages doivent s'effectuer facilement et sans forcer dans toutes les positions et rester en place une fois réalisés. Si les réglages sont difficiles à effectuer et ne restent pas en position, suivez les instructions pour desserrer ou resserrer la tension afin que les mouvements soient plus aisés. Selon le produit que vous utilisez et le réglage, il faut parfois effectuer plusieurs tours de vis avant de remarquer une différence.

Es ist von Bedeutung, dass Sie dieses Produkt entsprechend dem Gewicht des installierten Geräts wie in den folgenden Schritten beschrieben anpassen. Wenn Zubehör von diesem Produkt entfernt oder dazu hinzugefügt wird, was zu einer Änderung der Last führt, sollten Sie diese Einstellungsschritte wiederholen, um einen sicheren und optimalen Betrieb zu gewährleisten. • Einstellungen sollten über den gesamten Verstellbereich gleichmäßig und leicht durchzuführen sein und an der eingestellten Position verbleiben. Lassen sich die Einstellungen nur schwer durchführen oder bleibt das Gerät nicht in der gewünschten Position, folgen Sie der Anleitung und lockern oder verstärken Sie die Spannung für eine gleichmäßige und leichte Einstellung. Je nach Produkt und Einstellung muss dies mehrmals wiederholt werden, um einen Unterschied zu merken.

Het is belangrijk dat u dit product aanpast volgens het gewicht van de gemonteerde apparatuur zoals beschreven staat in de volgende stappen. Telkens als er apparatuur toegevoegd wordt aan of verwijderd wordt van dit product, wat een verandering van het gewicht van de gemonteerde belasting tot gevolg heeft, moet u deze aanpassingsstappen herhalen om een veilige en optimale werking te garanderen. • Verplaatsingen moeten soepel en eenvoudig over het volle bewegingsbereik mogelijk zijn, en de ingestelde positie moet gehandhaafd blijven. Als aanpassingen moeilijk zijn en de gewenste positie blijft niet gehandhaafd, dan volgt u de instructies om de spanning te verminderen of vergroten om een soepele, eenvoudige aanpassing mogelijk te maken. Al naargelang uw product en de gewenste aanpassing, kunnen een paar slagen nodig zijn om verschil te merken.

È importante regolare questo prodotto in base al peso dell'attrezzatura montata, come descritto nella procedura seguente. Ogni volta che si aggiungono o si rimuovono componenti da questo prodotto, variando quindi il peso del carico fissato, ripetere questa procedura di regolazione per garantire il funzionamento ottimale e in sicurezza. • I componenti a posizione regolabile devono essere spostabili in modo regolare e agevolmente per la loro intera corsa e rimanere fermi quando li si rilasciano. Se risulta difficile regolare la posizione di un componente o questo non rimane nella posizione desiderata, seguire le istruzioni per ridurre o aumentare la tensione di bloccaggio affinché il movimento risulti agevole e facilmente regolabile. A seconda del prodotto e del tipo di regolazione, possono essere necessarie più corse prima di notare una differenza.

Det är viktigt att du justerar denna produkt enligt den monterade utrustningens vikt, som beskrivet i följande steg. När utrustning läggs till eller tas bort från denna produkt och vikten av den monterade belastningen förändras, bör du upprepa dessa justeringar för att säkerställa säker och optimal drift.

Justeringar ska röra sig smidigt och lätt genom hela uppsättningen rörelser, och stanna där du ställer in dem. Om justeringarna är besvärliga och inte stannar i önskad position, följ instruktionerna om att lossa på eller skruva åt skruvar för att skapa en smidig och lätt justeringsrörelse. Beroende på din produkt, och på justeringen, kan det ta flera varv innan man märker någon skillnad.

この製品は、取り付けた機器の重量に応じて次の手順で調整してください。この製品に機器を取り付けたり、取り外したりして重量が変わった場合は、安全かつ最適な操作を保証するために同じ手順をふたたび実行してください。

調整は可動域内でスムーズかつ簡単に動く必要があり、選定した位置にしっかり固定されなければなりません。調整の動きがごちなく、選定位置で固定されない場合は、調整がスムーズにできるよう、説明書に従って張力を増減します。お使いの製品や調整によっては、違いがはっきりするまで何回か回さなければならないこともあります。

调节应当在整个动作范围内灵活自如，并能固定在所调整的位置。如果调节困难且不能固定在想要的位置上，请遵照说明书拧松或拧紧，使调节动作灵活自如。根据您所用产品及调节方式，可能需要旋转几圈后才能注意到差别。



Lift – Up and down
Elevación (arriba y abajo)
Ajustement en hauteur : bas et haut
Höhenverstellung – rauf und runter
Verstel in hoogte – Omhoog en omlaag
Sollevamento – Su e Giù
Lyft – upp och ned
リフト(上下)
升降 (上下)
높이 (위/아래로)

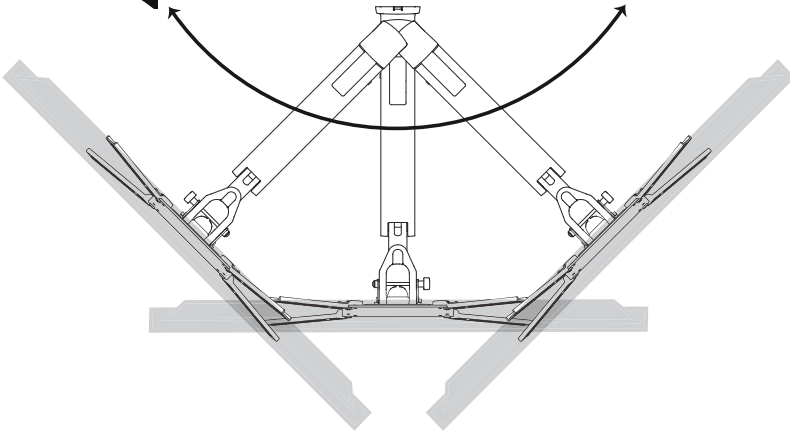
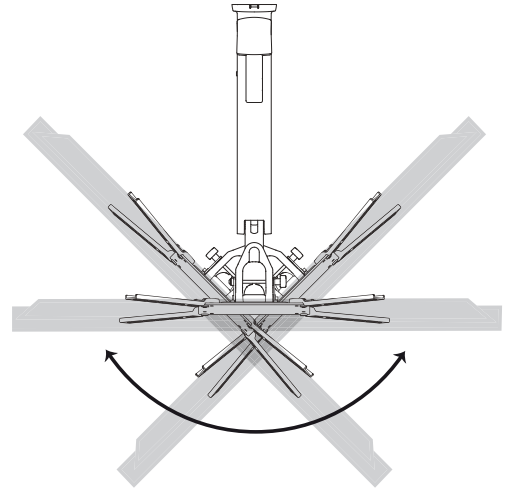
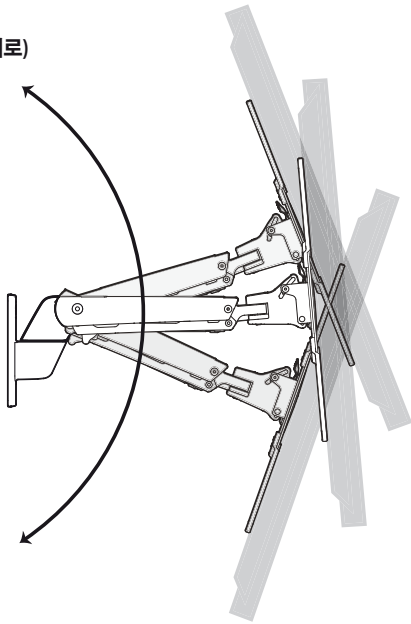

Tilt – Forward and Backward
Inclinación (adelante y atrás)
Inclinaison : Avant et arrière
Neigung – vor und zurück
Kantel – Naar voren en naar achteren
Inclinazione – Avanti ed Indietro
Vinkla – framåt och bakåt
チルト (前後)
傾斜 (前後)
기울기 - 앞/뒤로

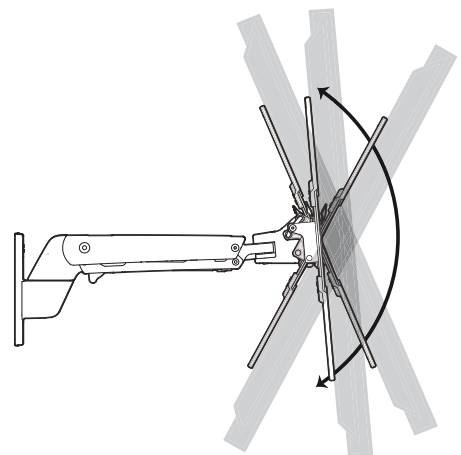



Lift – Up and down
Elevación (arriba y abajo)
Ajustement en hauteur : bas et haut
Höhenverstellung – rauf und runter
Verstel in hoogte – Omhoog en omlaag
Sollevamento – Su e Giù
Lyft – upp och ned
リフト(上下)
升降 (上下)
높이 (위/아래로)

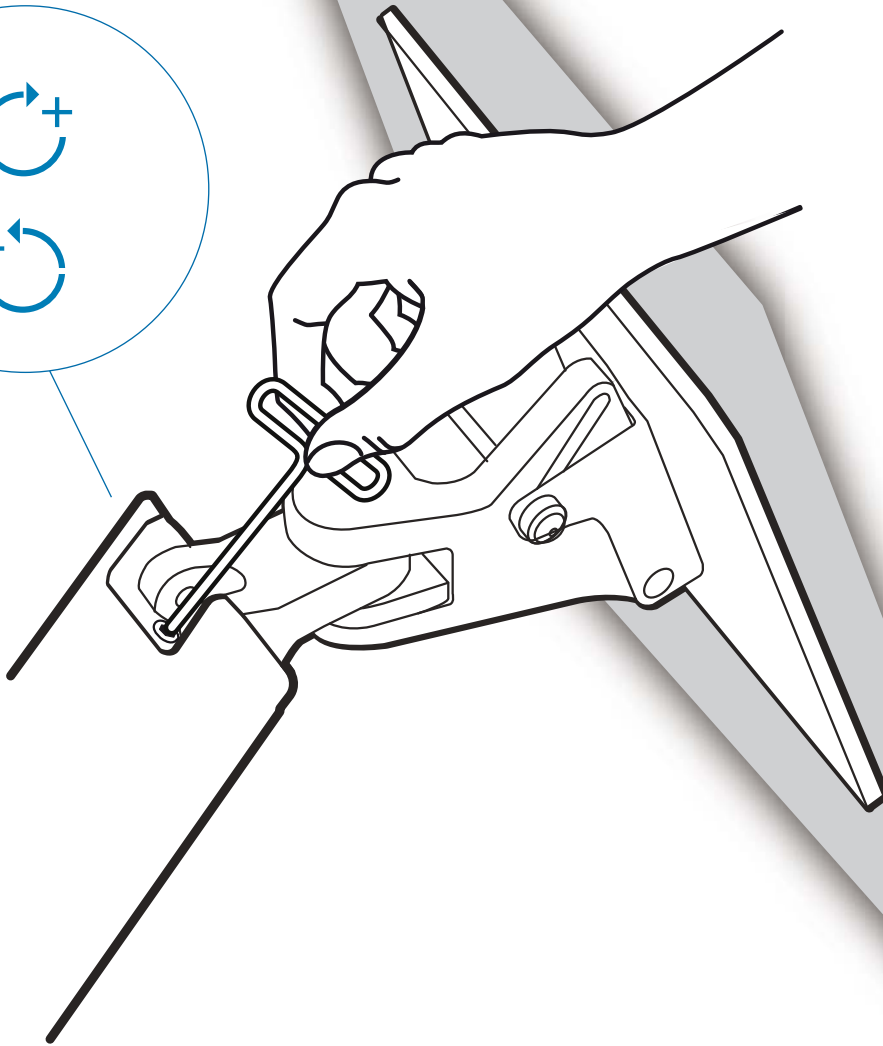
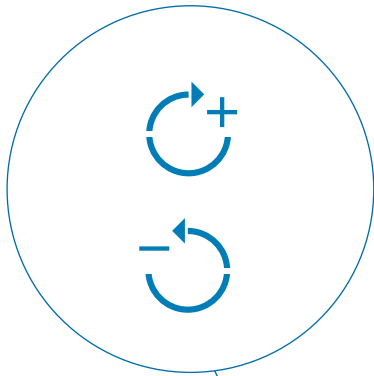
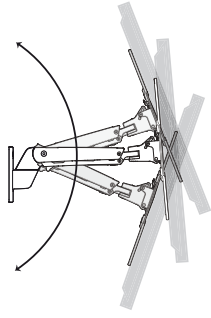

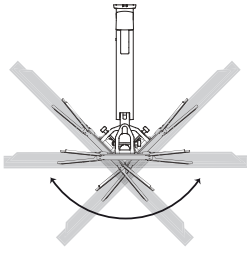

1

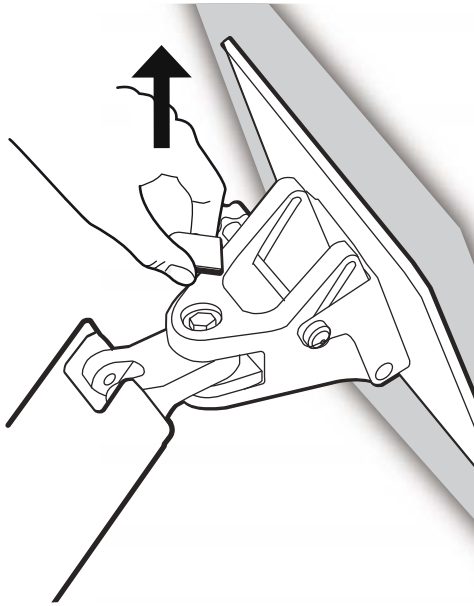

2

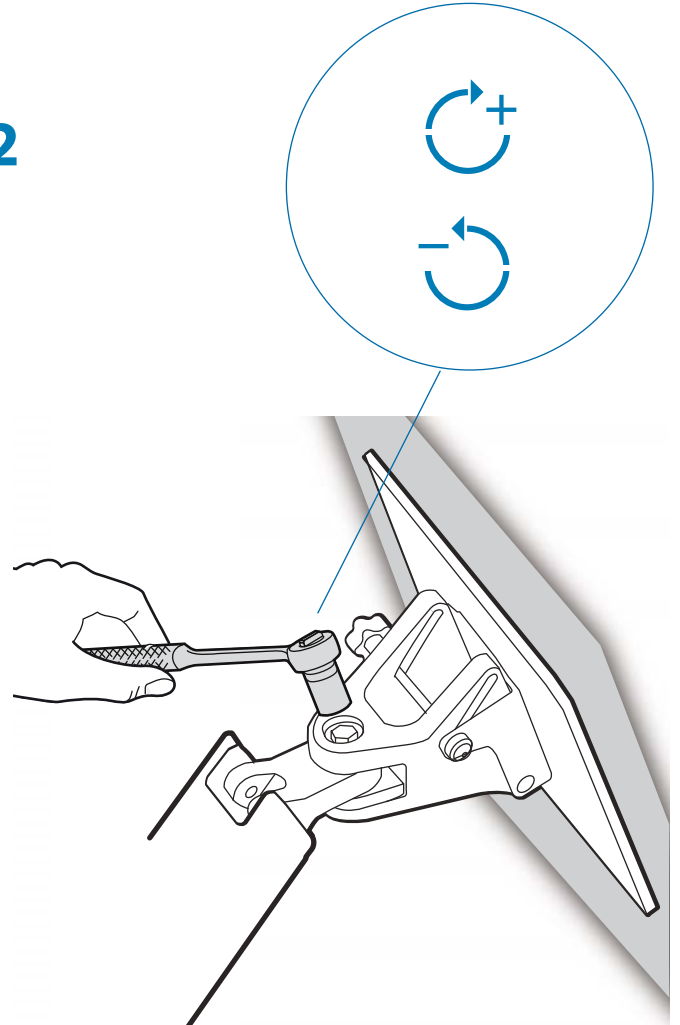

3

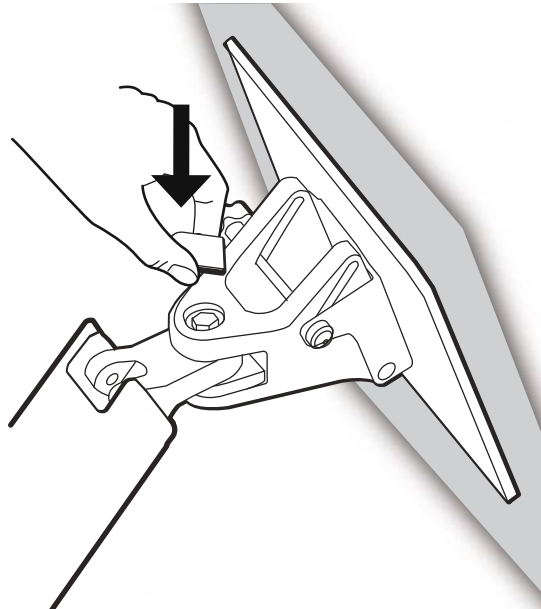

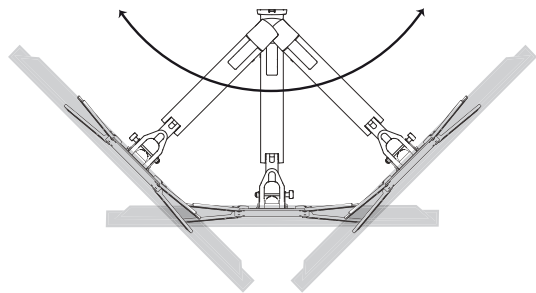

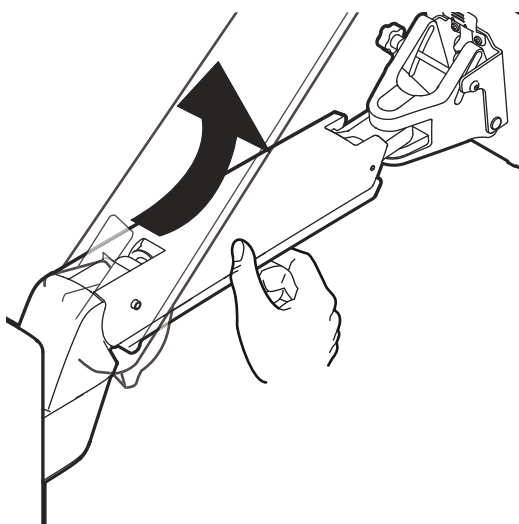

1

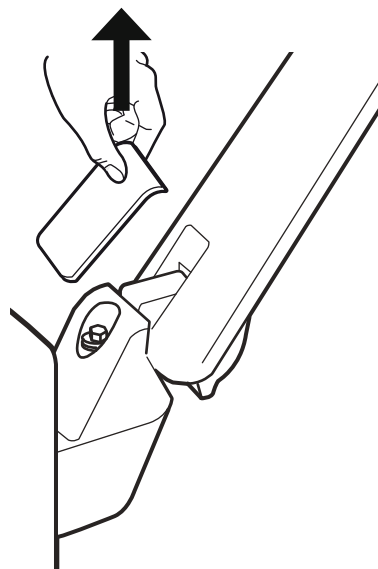

2



3

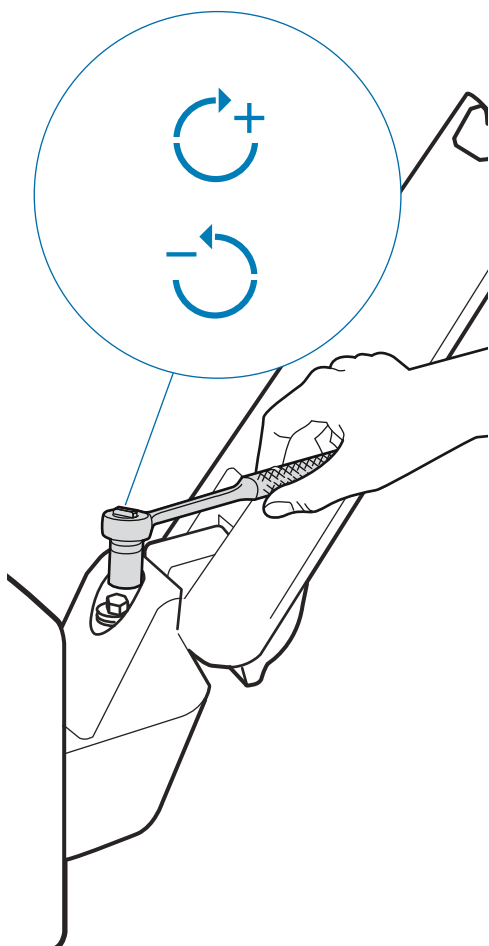

CAUTION! The bottom nut will turn during adjustment of the top nut; DO NOT apply any tool to the bottom nut. Serious damage to the Arm may occur if these instructions are not followed.

PRECAUCIÓN La tuerca inferior gira mientras se ajusta la tuerca superior; NO aplique ninguna herramienta a la tuerca inferior. Si no sigue estas instrucciones, el brazo puede sufrir daños graves.

ATTENTION ! L'écrou du bas tournera pendant l'ajustement de celui du haut; n'utiliser AUCUN outil sur l'écrou du bas. Le bras pourrait être sérieusement endommagé dans le cas où ces instructions ne seraient pas suivies.

VORSICHT! Beim Drehen der oberen Mutter dreht sich auch die untere Mutter. Fixieren Sie die untere Mutter **AUF KEINEN FALL**. Bei Nichteinhaltung dieser Anweisung kann es zu erheblichen Schäden am Arm kommen.

VOORZICHTIG! Tijdens het aanpassen van de bovenste moer draait de onderste moer mee. **GEBRUIK GEEN GEREEDSCHAP** op de onderste moer. Er kan ernstige schade aan de arm optreden als deze instructies niet opgevolgd worden.

ATTENZIONE Il dado inferiore gira durante la regolazione del dado superiore; **NON** applicare nessun attrezzo al dado inferiore. Se non si seguono queste istruzioni, si possono causare danni gravi al braccio.

WARNING: Den undre muttern kommer att rotera under justering av den övre muttern – använd **INTE** något verktyg på den undre muttern. Det kan uppstå allvarliga skador på armen om dessa instruktioner inte åtföljs.

注意! 上部のナットを調節する際に下部のナットも回転します。下部のナットには、工具などを一切使用しないでください。この指示を無視すると、アームに重大な損傷を与える可能性があります。

小心! 调整上端螺母时底部螺母将会转动; 请勿在底部螺母上使用任何工具。不遵守此指示可能导致支臂严重损坏。



Tilt – Forward and Backward
Inclinación (adelante y atrás)
Inclinaison : Avant et arrière
Neigung – vor und zurück
Kantel – Naar voren en naar achteren
Inclinazione – Avanti ed indietro
Vinkla – framåt och bakåt
チルト (前後)
傾斜 (前後)
기울기 - 앞/뒤로

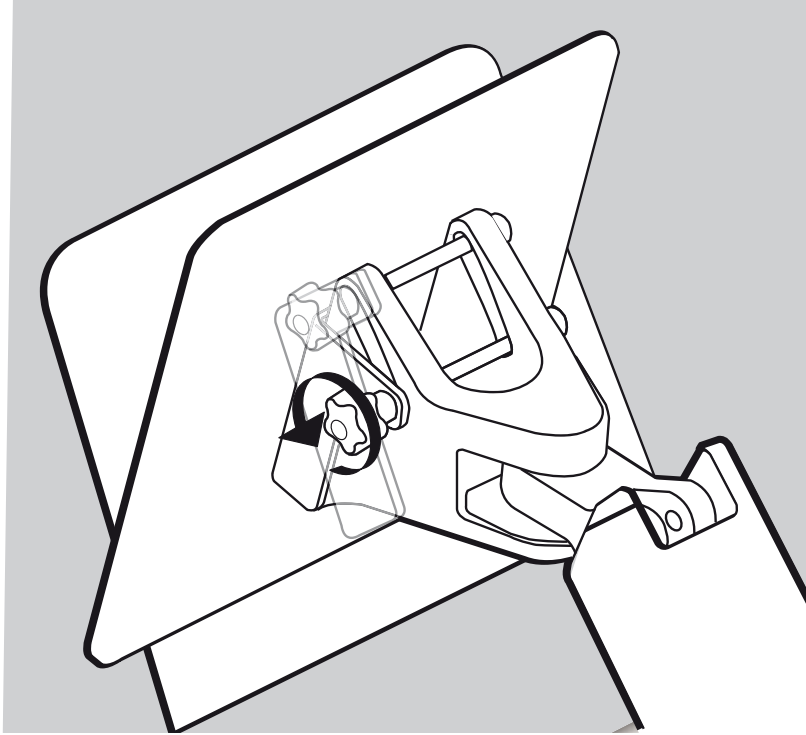
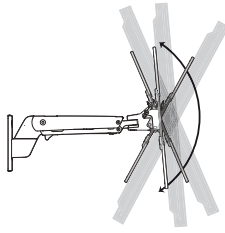

© 2011 Ergotron, Inc.
All rights reserved.

While Ergotron, Inc. makes every effort to provide accurate and complete information on the installation and use of its products, it will not be held liable for any editorial errors or omissions (including those made in the process of translation from English to another language), or for incidental, special or consequential damages of any nature resulting from furnishing this instruction and performance of equipment in connection with this instruction. Ergotron, Inc. reserves the right to make changes in the product design and/or product documentation without notification to its users. For the most current product information, or to know if this document is available in languages other than those herein, please contact Ergotron. No part of this publication may be reproduced, stored in a retrieval system, or transmitted in any form or by any means, electronic, mechanical, photocopying, recording or otherwise without the prior written consent of Ergotron, Inc., 1181 Trapp Road, Eagan, Minnesota, 55121, USA. Patents Pending and Patented U.S. & Foreign. Ergotron is a registered trademark of Ergotron, Inc.

**Americas Sales and
Corporate Headquarters**

St. Paul, MN USA
(800) 888-8458
+1-651-681-7600
www.ergotron.com
sales@ergotron.com

EMEA Sales

Amersfoort, The Netherlands
+31 33 45 45 600
www.ergotron.com
info.eu@ergotron.com

APAC Sales

Tokyo, Japan
www.ergotron.com
apaccustomerservice@ergotron.com

Worldwide OEM Sales

www.ergotron.com
info.oem@ergotron.com