

peerless-AV[®]

DS-C555-3X3

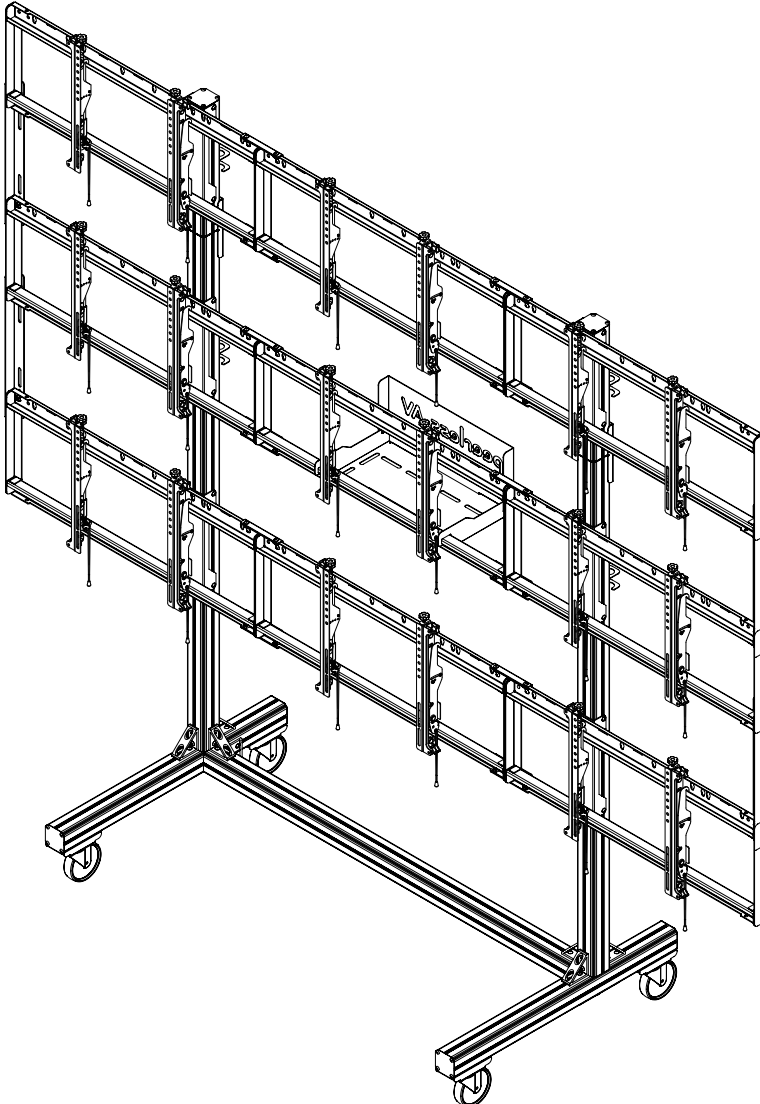
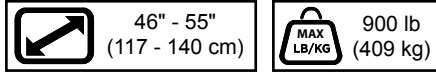

ENG This page intentionally left blank.

▲ WARNING

ENG - Do not begin to install product until you have read and understood the instructions and warnings contained in this user guide. Always use an assistant or mechanical lifting equipment to safely lift and position equipment. This product must be installed onto flat, hard, level surface to prevent tipping. Use with heavier displays may result in instability causing tip over resulting in death or serious injury. The cart or stand is not affixed or secured to the floor, and may therefore tip over and/or fall if screen and/or stand is shaken or hit. This product is intended for indoor use only. Use of this product outdoors could lead to product failure or personal injury. Screws must be tightly secured. Do not overtighten screws or damage can occur and product may fail. Never exceed the Maximum Load Capacity. Be careful not to pinch fingers when operating the mount. Death or serious injury may occur when children climb on audio and/or video equipment furniture. A remote control or toys placed on the furnishing may encourage a child to climb on the furnishing and as a result the furnishing may tip over on to the child. Relocating audio and/or video equipment to furniture not specifically designed to support audio and/or video equipment may result in death or serious injury due to the furnishing collapsing or over turning onto a child. For support please call customer care at 1-800-865-2112.

ENG Symbols



ENG WARNING



ENG Screws must get at least three full turns and fit snug.



ENG Display center.

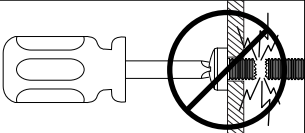

ENG Do not overtighten screws.



To properly tighten screws: Tighten until screw head makes contact, then tighten another 1/2 turn. Do not overtighten screws.

1

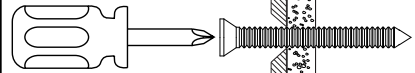

2

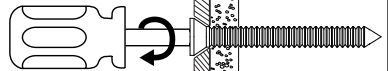

3

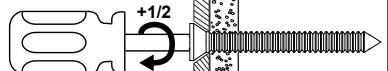

4



Parts (Before beginning, make sure you have all parts shown below).

Parts List

Description	Qty	Part #
A caster, 5" swivel	4	600-0026
B caster support	4	145-T1799
C cover	6	145-T1809
D base leg	2	145-T1767
E horizontal leg support	1	145-T1785
F base support tube	2	145-T1812
G base support	8	560-T1261
H vertical leg support	2	146-T1131
I leg support extension	2	145-T1778
J left adaptor bracket	9	146-1609
K right adaptor bracket	9	146-1608
L side support bracket	4	145-T1807
M vertical support bracket	6	145-T1806
N computer cover	1	145-T1930
O computer shelf	1	145-T1931
P dual cross support	3	146-T1905
Q cross support	3	146-T1904
R extension adaptor	2	145-T1935
S cord bracket	4	146-T1321
T knurled knob	4	560-1160
U plate connections	6	145-T1821
V M8 x 16mm socket button screw	176	520-9527
W M8 square nut	66	530-1066
X cover clip	24	590-0317
Y M5 x 10mm type-F, socket pin screw	20	520-1164
Z bar nut	20	146-1319
AA 1/4" power bit	1	560-0263
BB 5mm allen wrench	1	560-9640
CC nylon shoulder washer	36	590-2233
DD M6 x 12mm socket pin screw	36	520-1050
EE 4mm allen wrench	1	560-9646
FF M8 x 20mm screw	6	520-1754

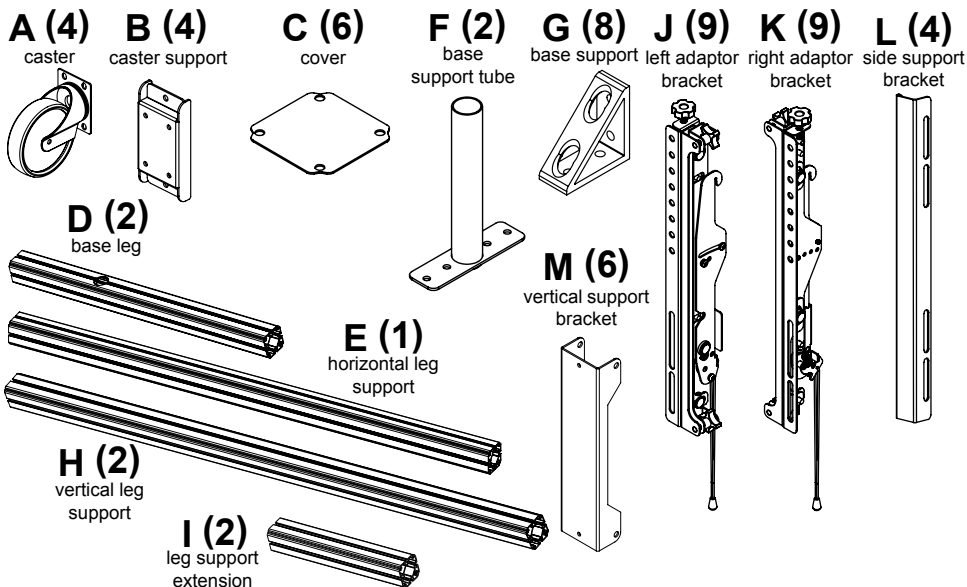

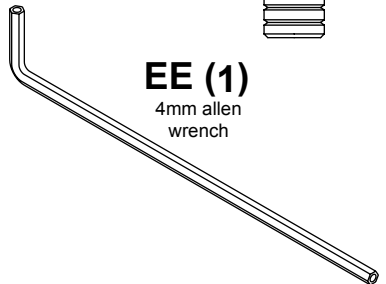
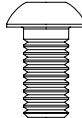
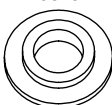
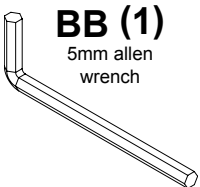
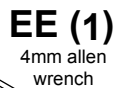
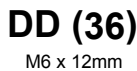
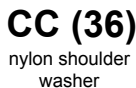
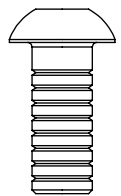
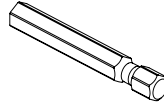
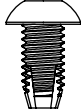
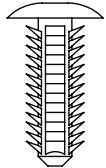
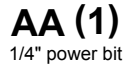
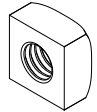
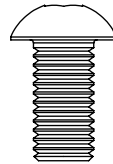
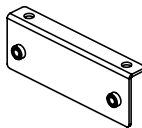
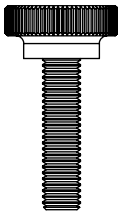
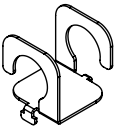
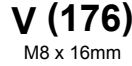
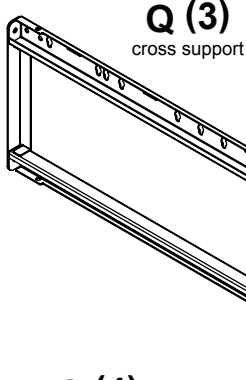
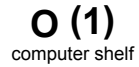

1-1

x4

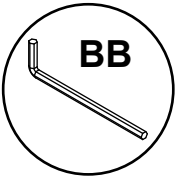

V (4)

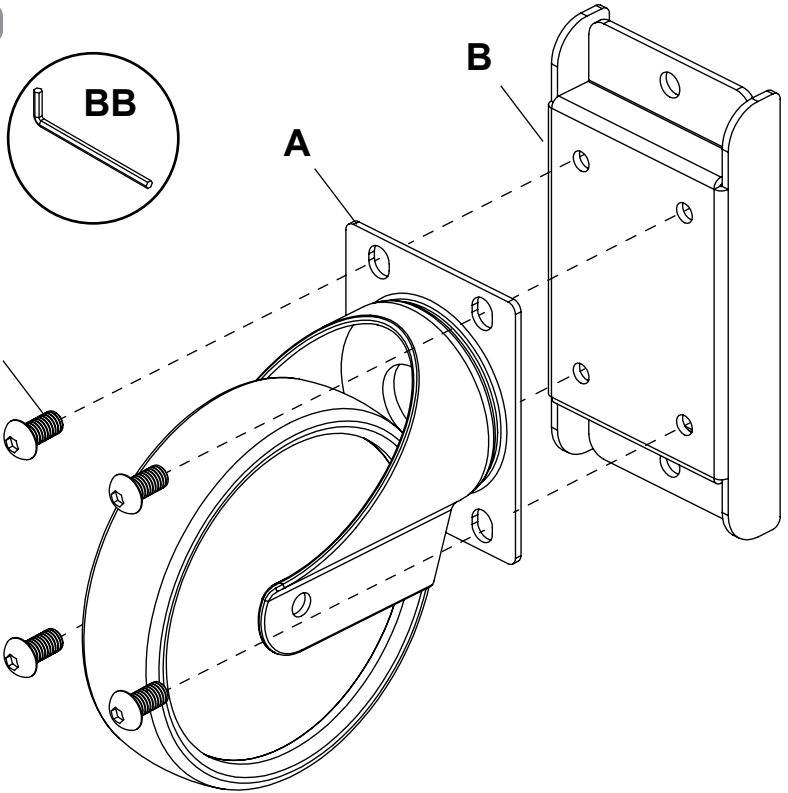

1-2

x4

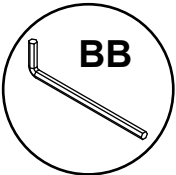

W (2)

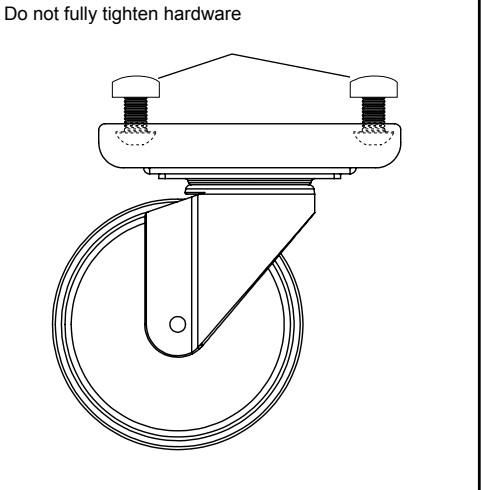

V (2)

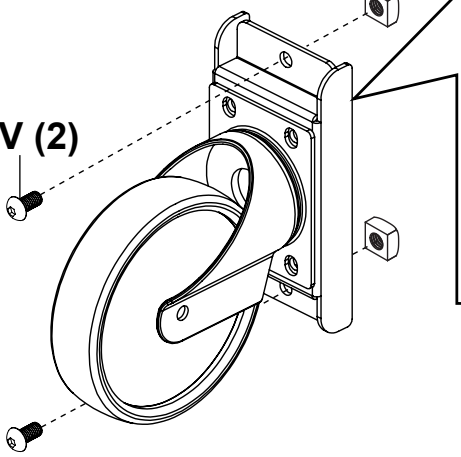

SIDE VIEW

x2

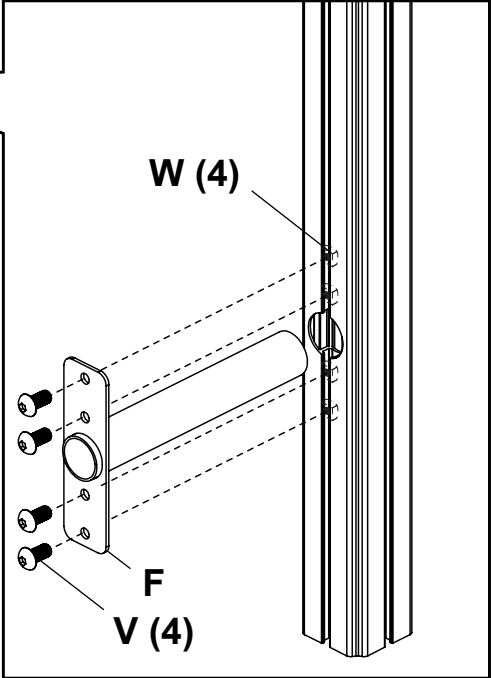
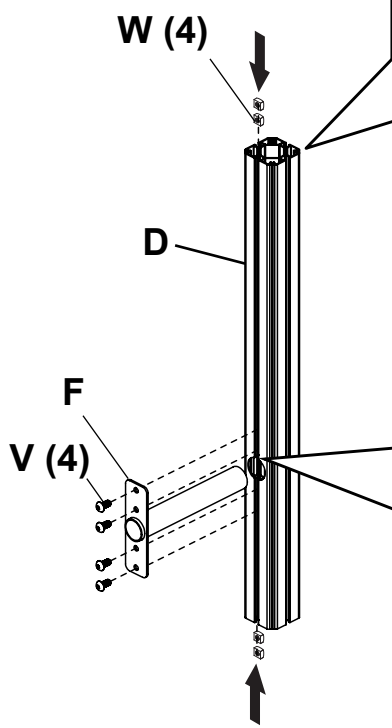
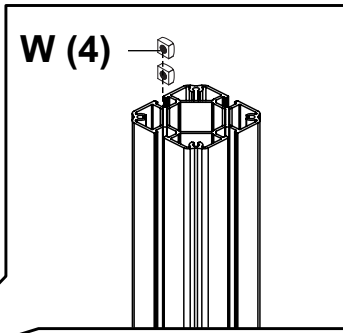
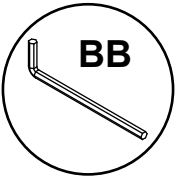

3

x2

BB

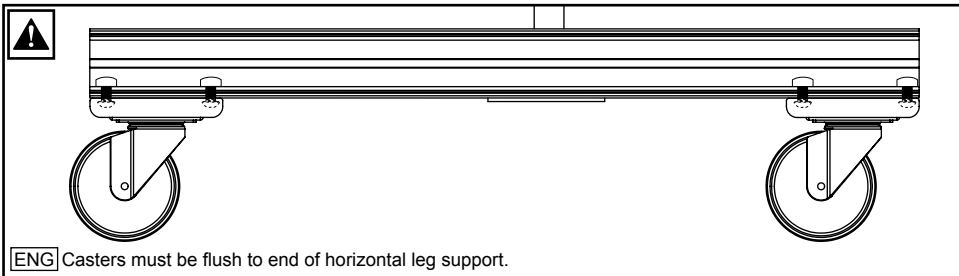
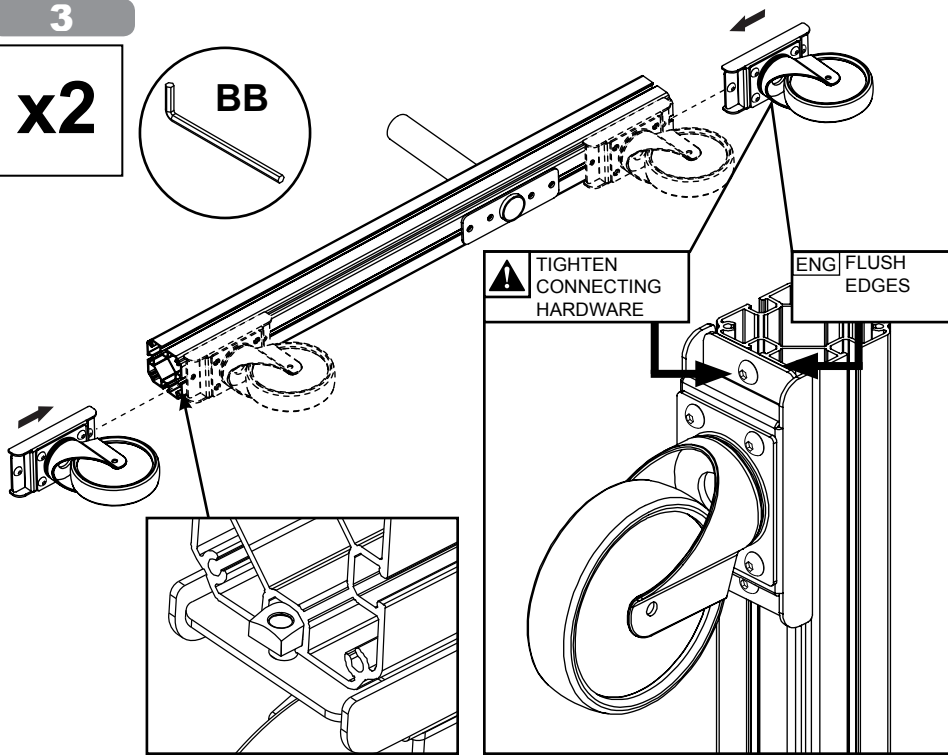

4

x8

BB

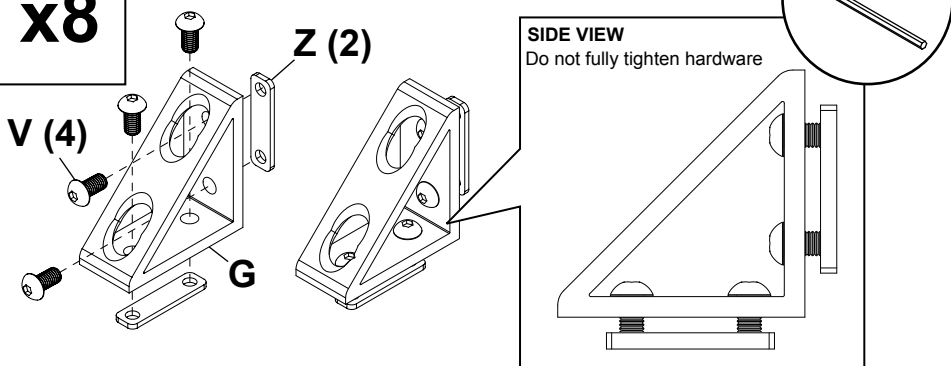

5

x2

BB

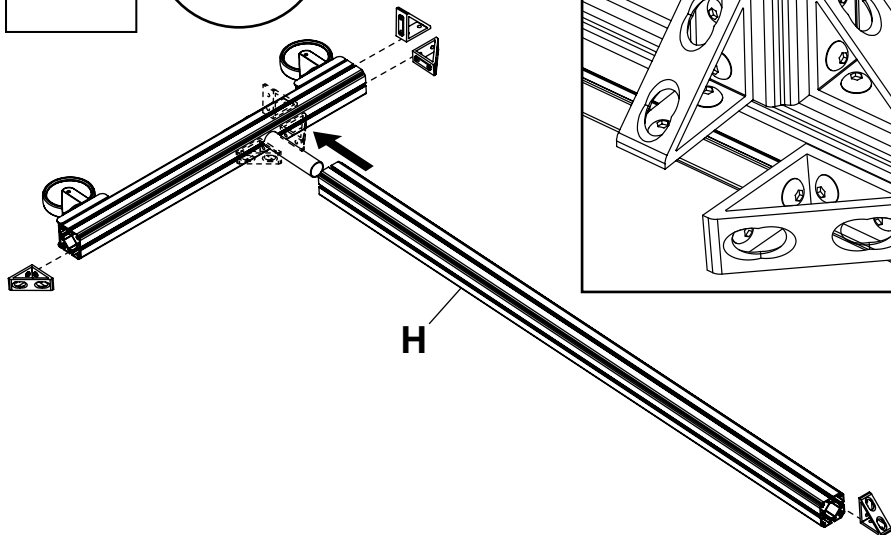

6

LOCK WHEELS

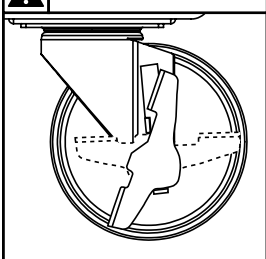

TIGHTEN CONNECTING HARDWARE

BB

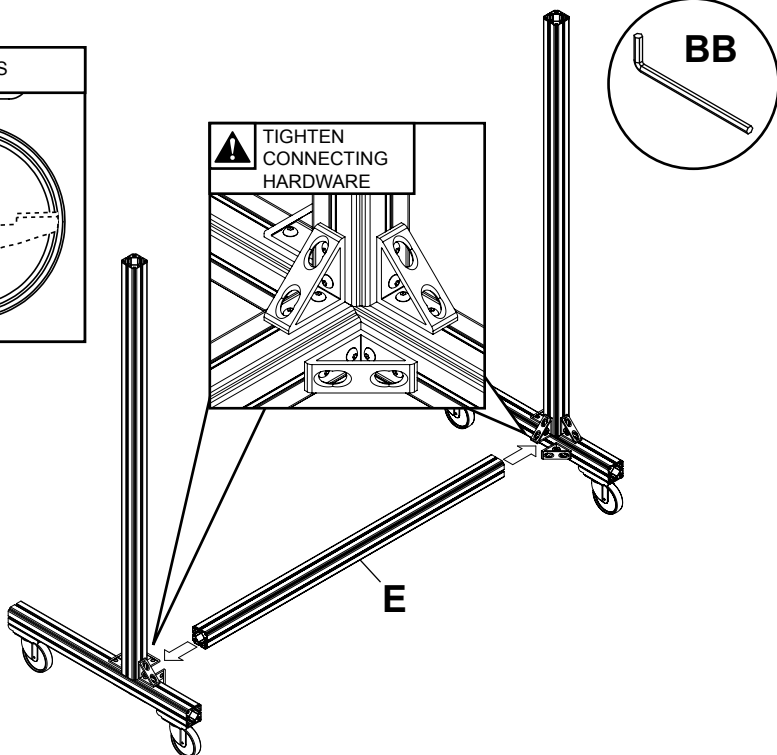

7-1

x2

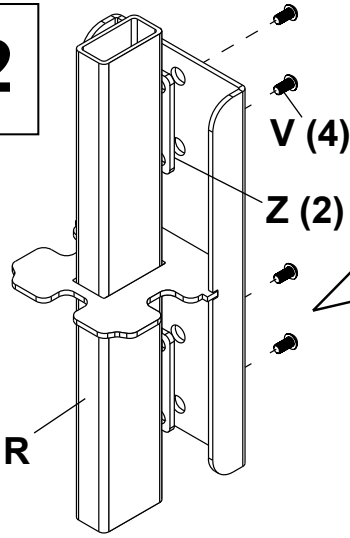

Do not fully tighten hardware

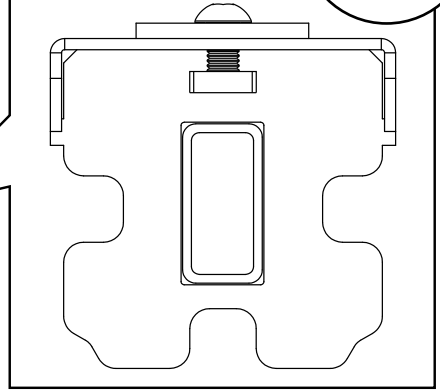

TOP VIEW

7-2

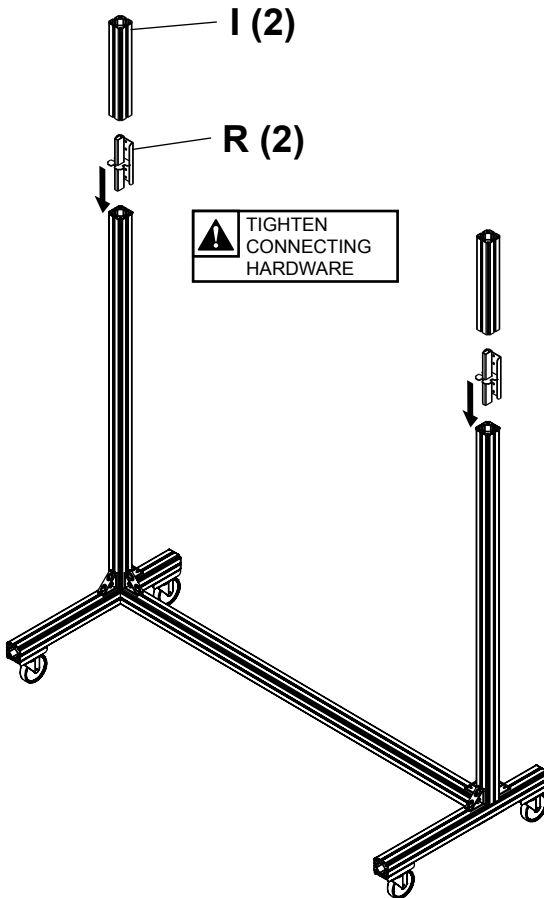

8-1

x6

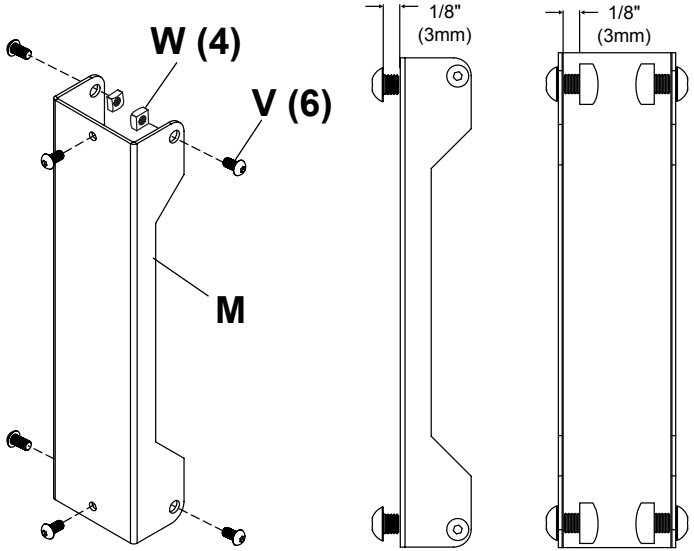

8-2

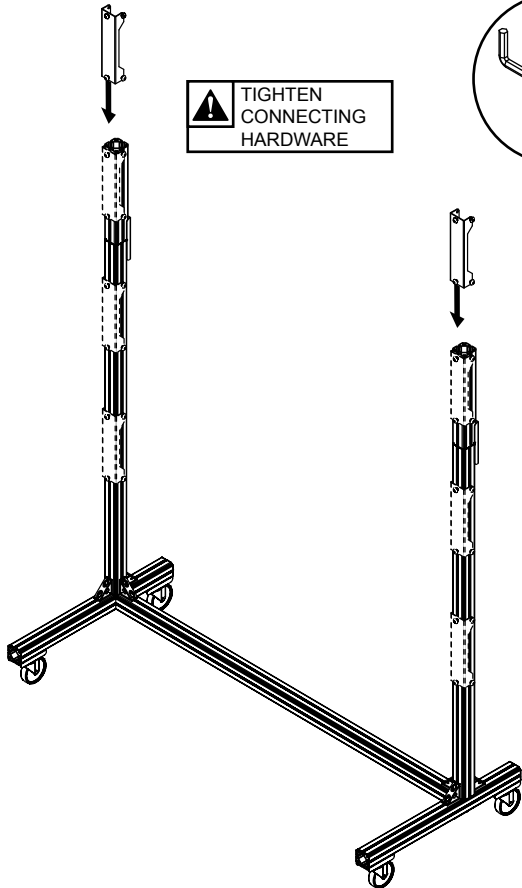
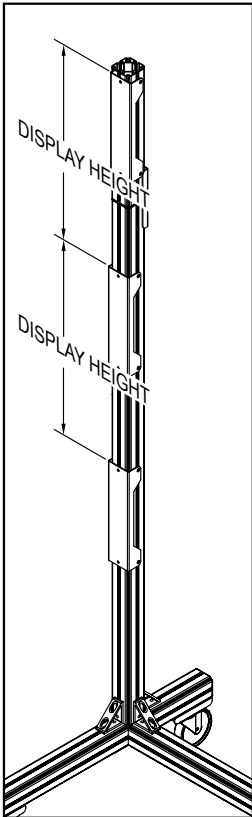

9-1

x3

BB

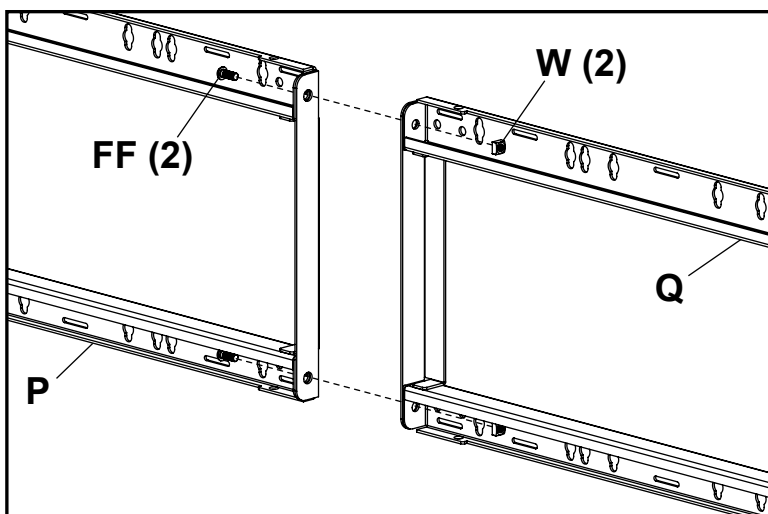

9-2

x3

BB

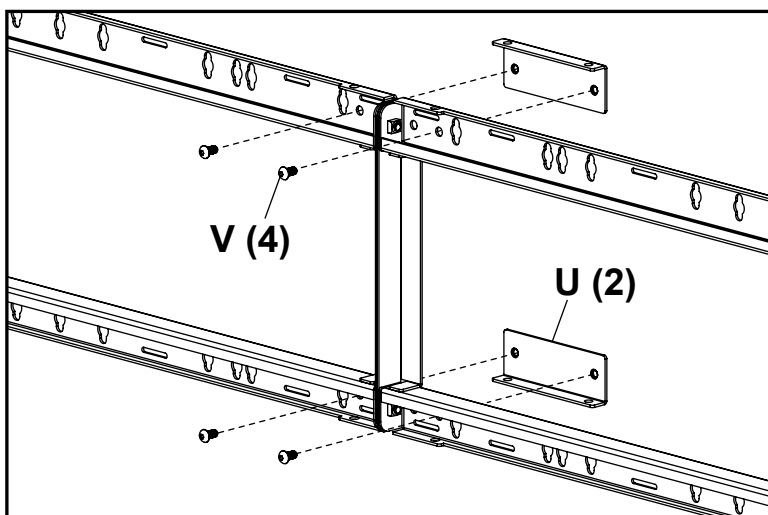

9-3

x3

BB

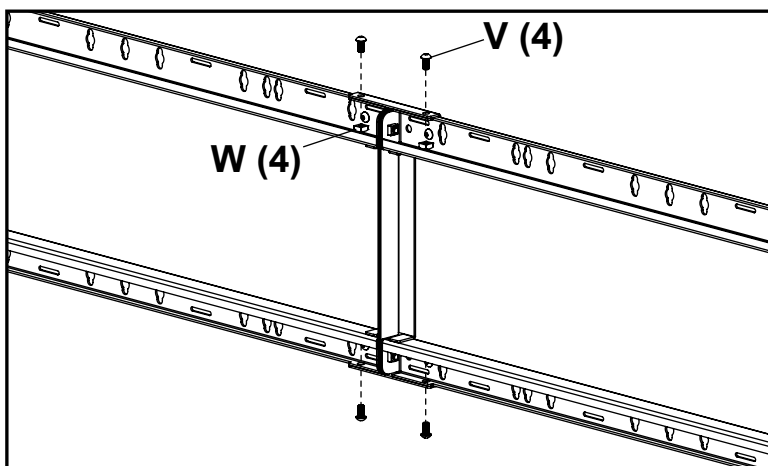

10

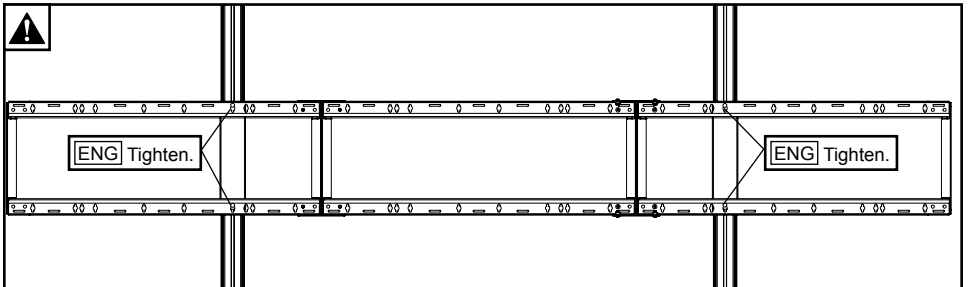
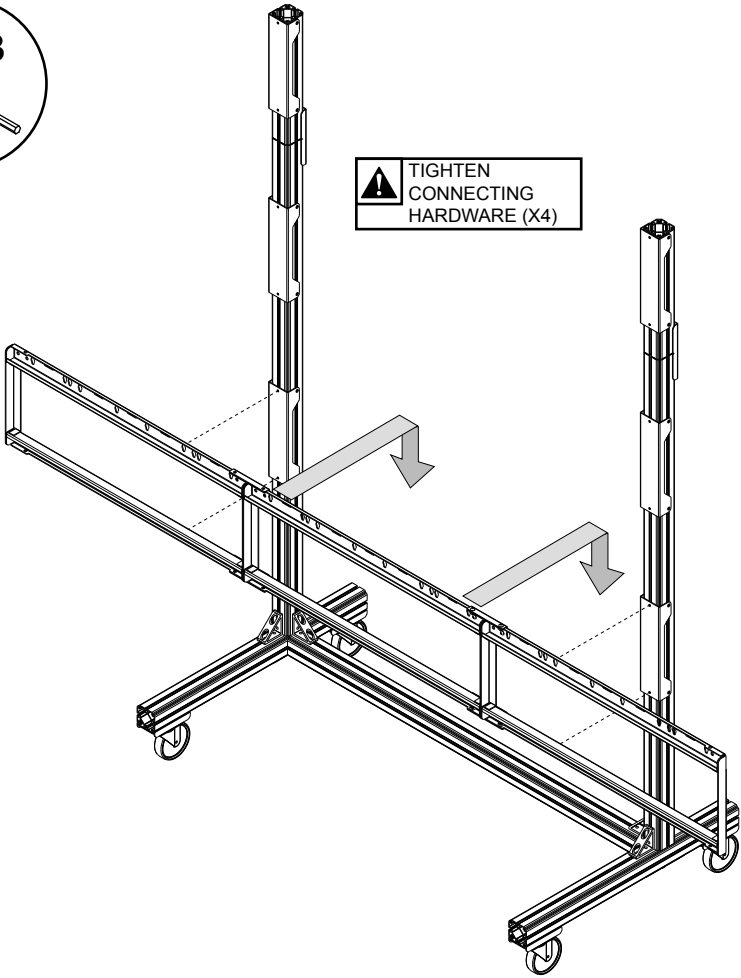
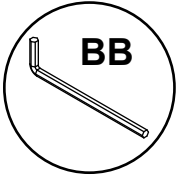

Cross supports must center on vertical leg supports.

11

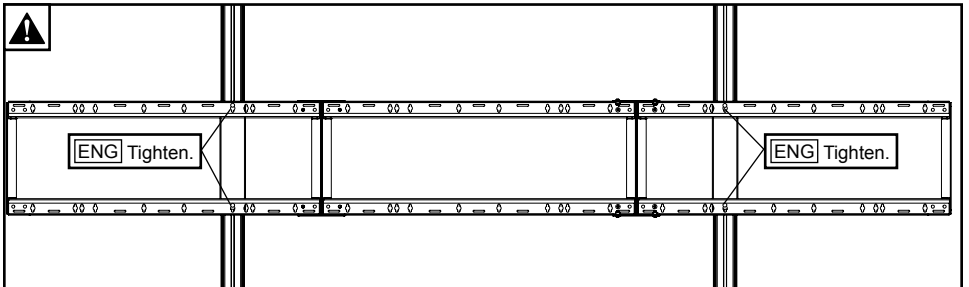
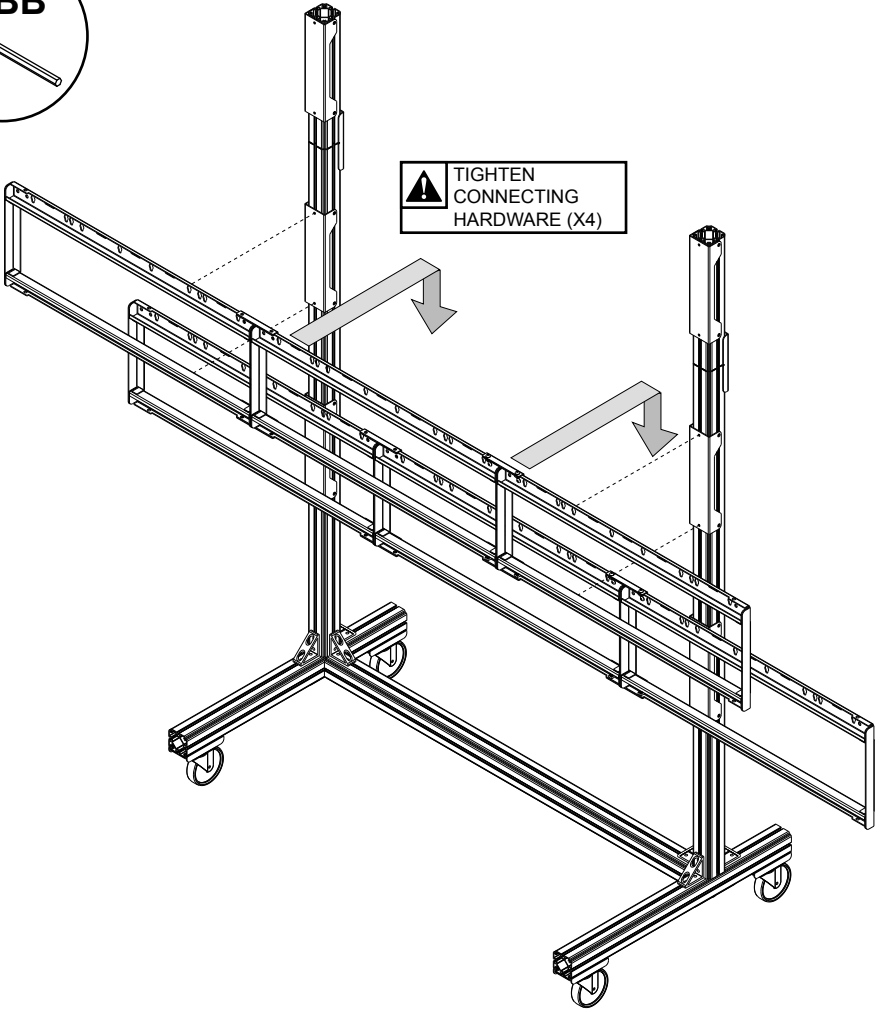
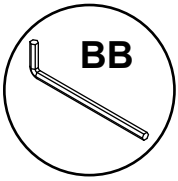

Cross supports must center on vertical leg supports.

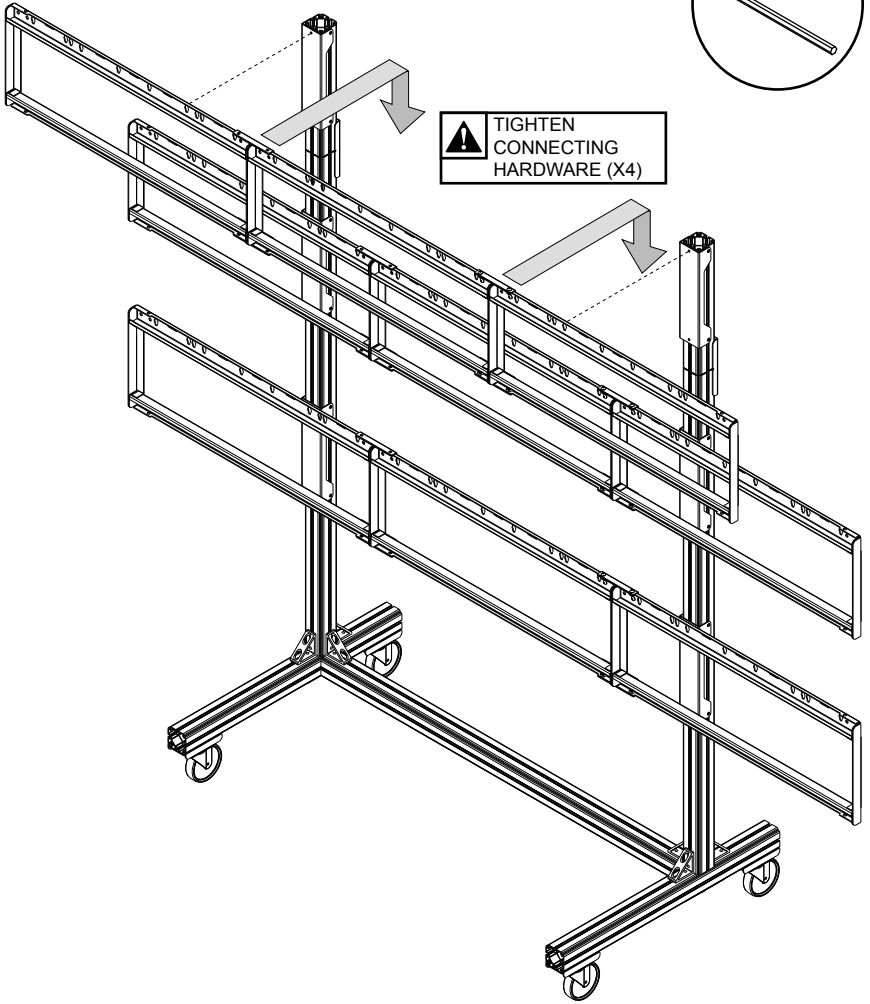
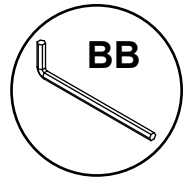

 TIGHTEN
CONNECTING
HARDWARE (X4)

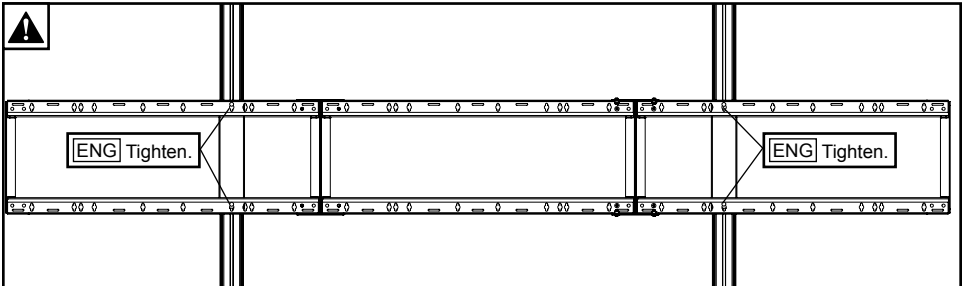

Cross supports must center on vertical leg supports.

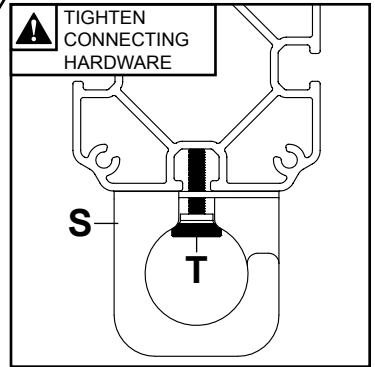
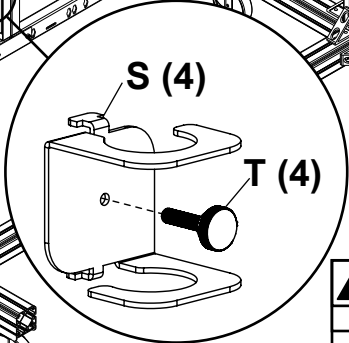
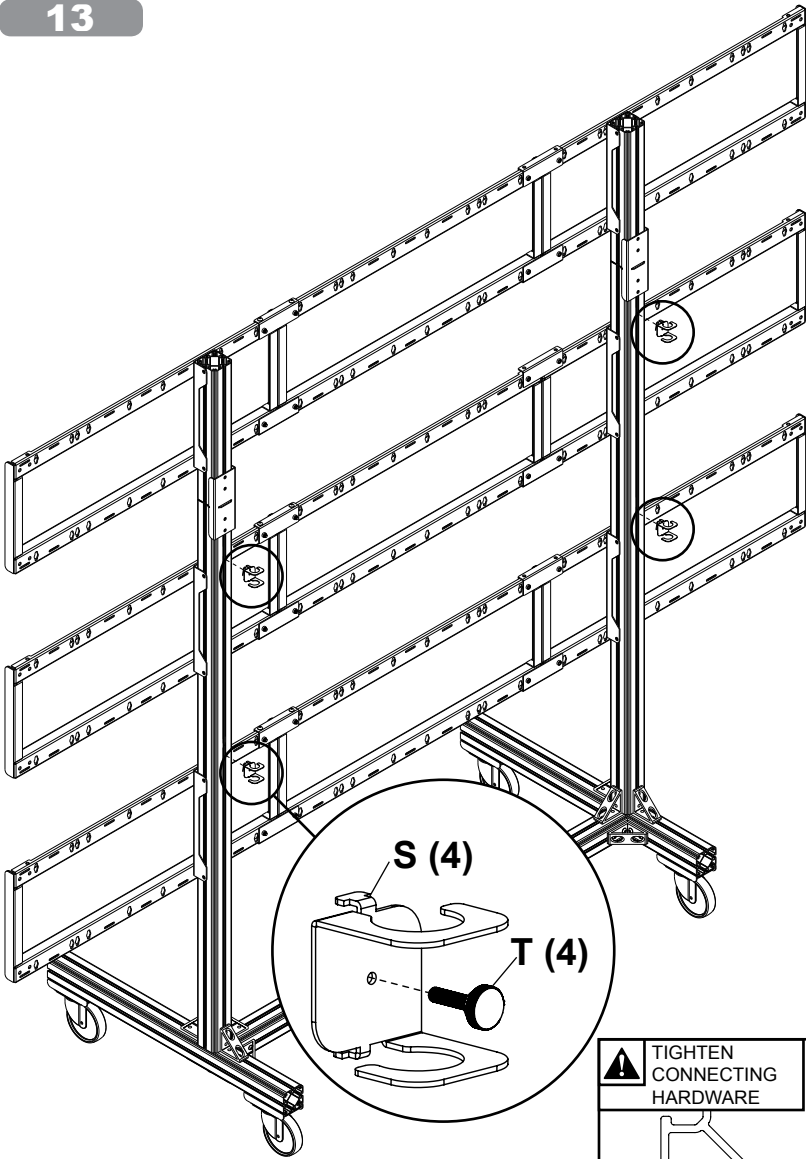

TOP VIEW

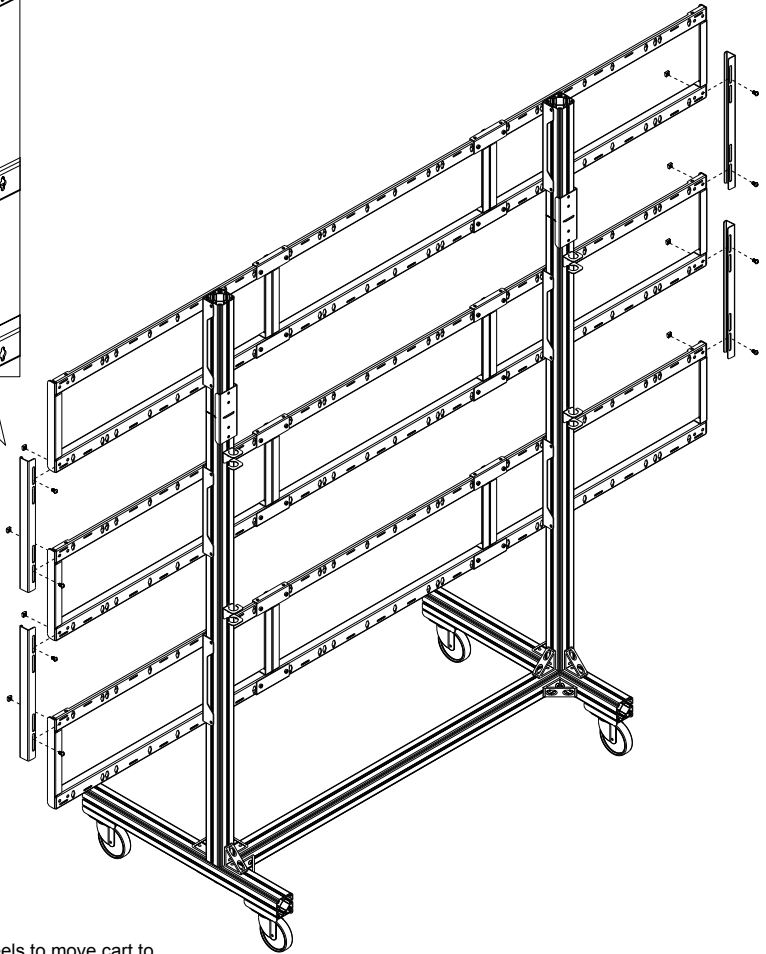
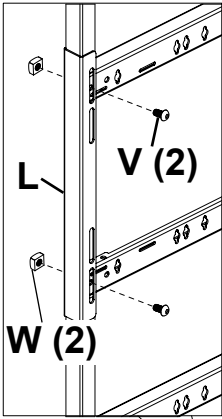
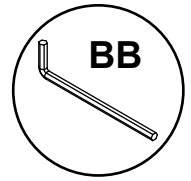

OPTIONAL: Unlock wheels to move cart to desired location; Lock wheels before hanging screens.

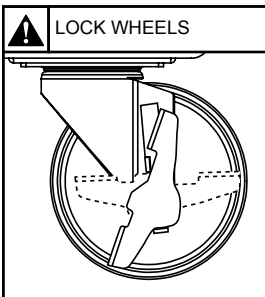

15-1

x9

ENG Center adapter brackets vertically on back of screen.

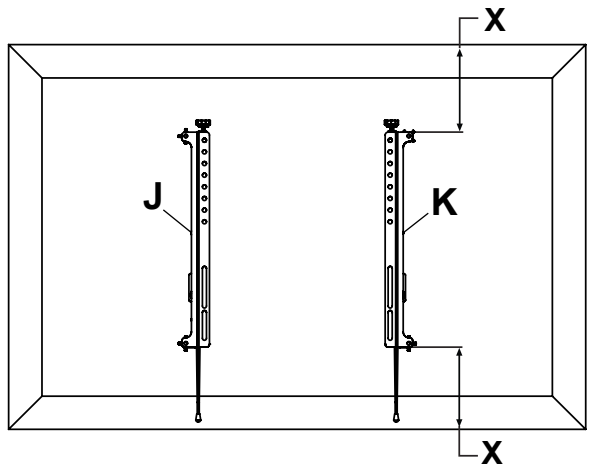

15-2

x9

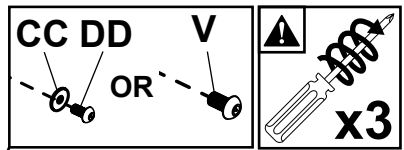
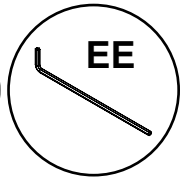
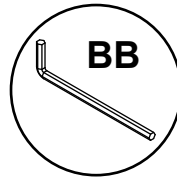
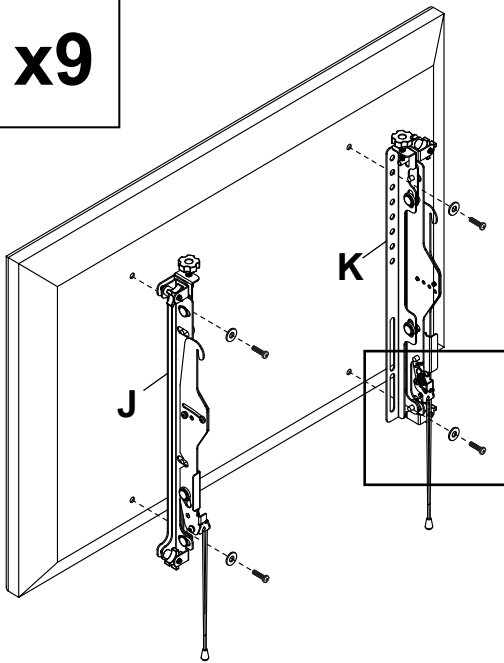

16-1

Must hang displays to bottom row first; Secure pin in "locked" position.

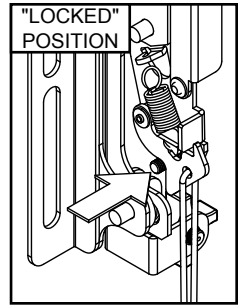
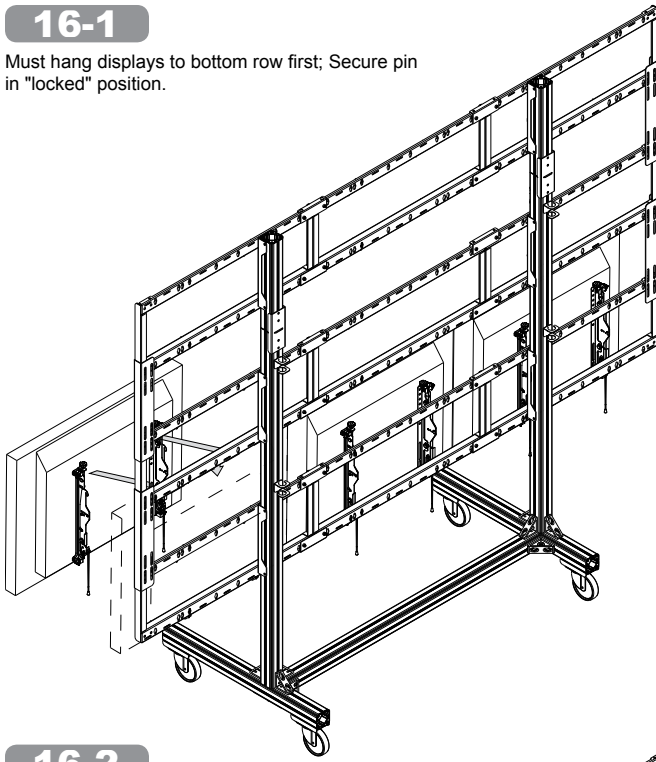

16-2

Must hang displays to middle row second; Secure pin in "locked" position.

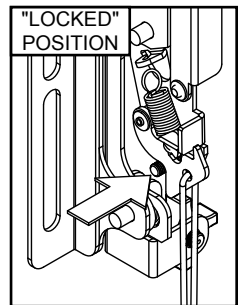
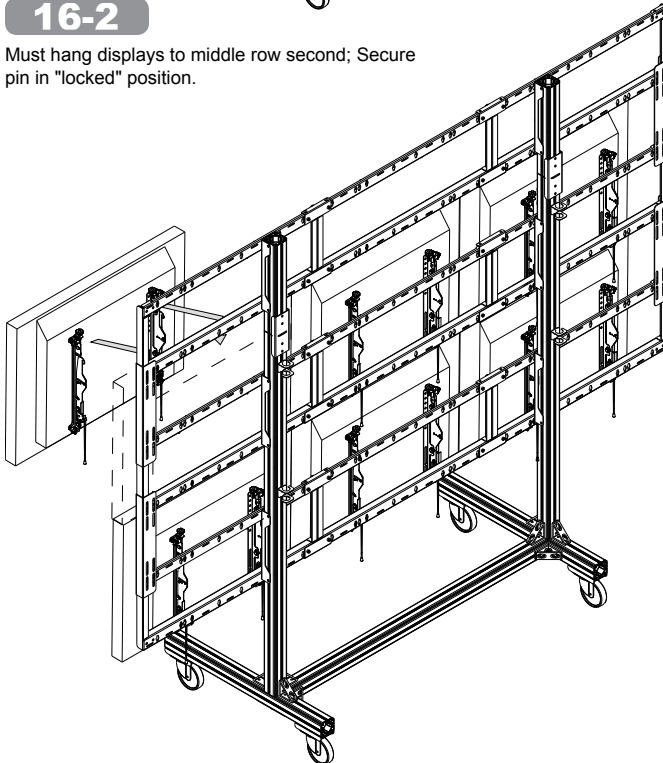

16-3

Must hang displays to top row last; Secure pin in "locked" position.

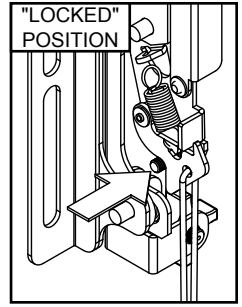
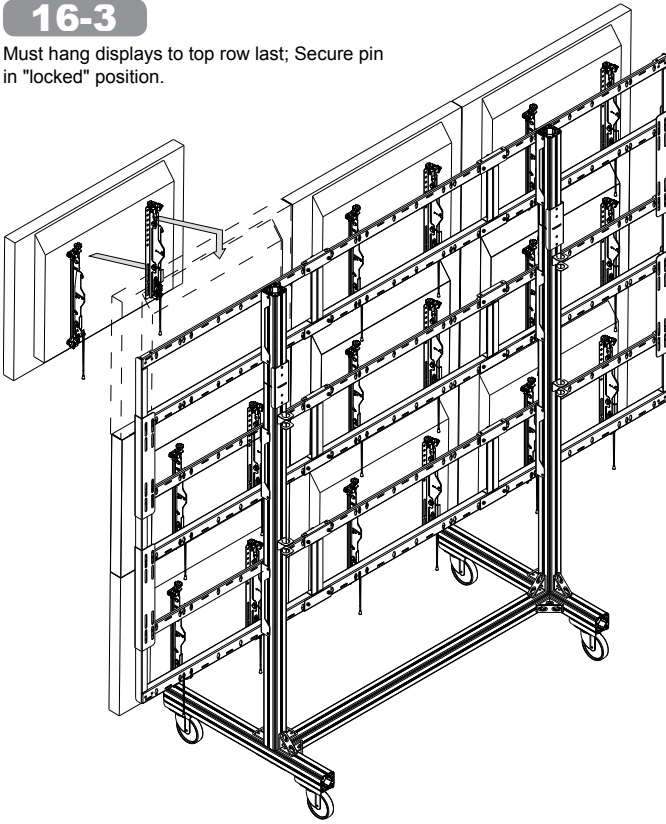

17

OPTIONAL: Insert M5 x 10mm type-F socket pin screws (Y) to lock latches.

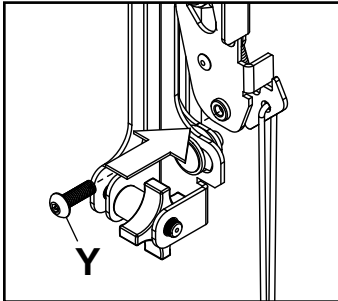

x18

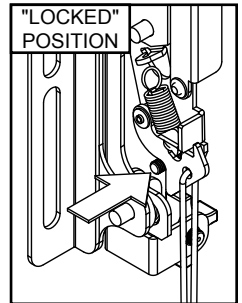
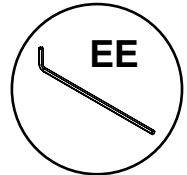

Display Adjustment

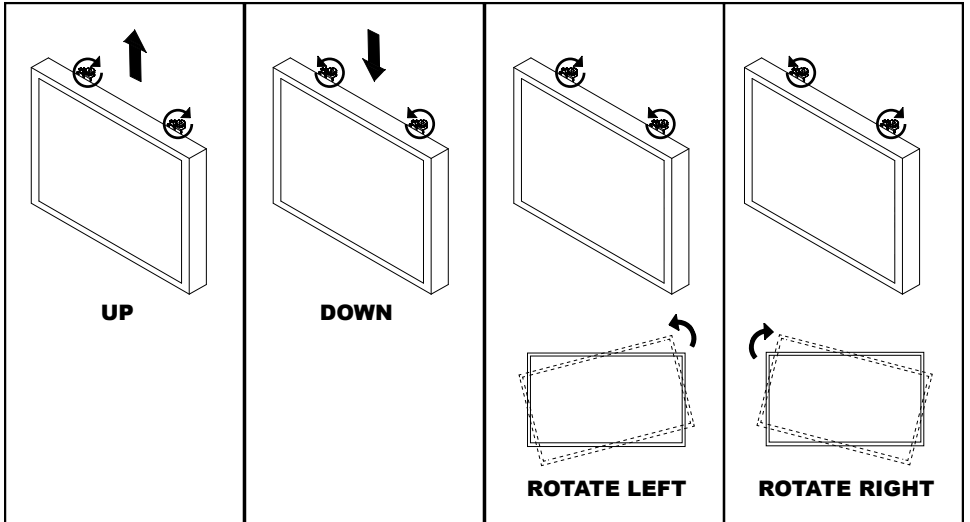
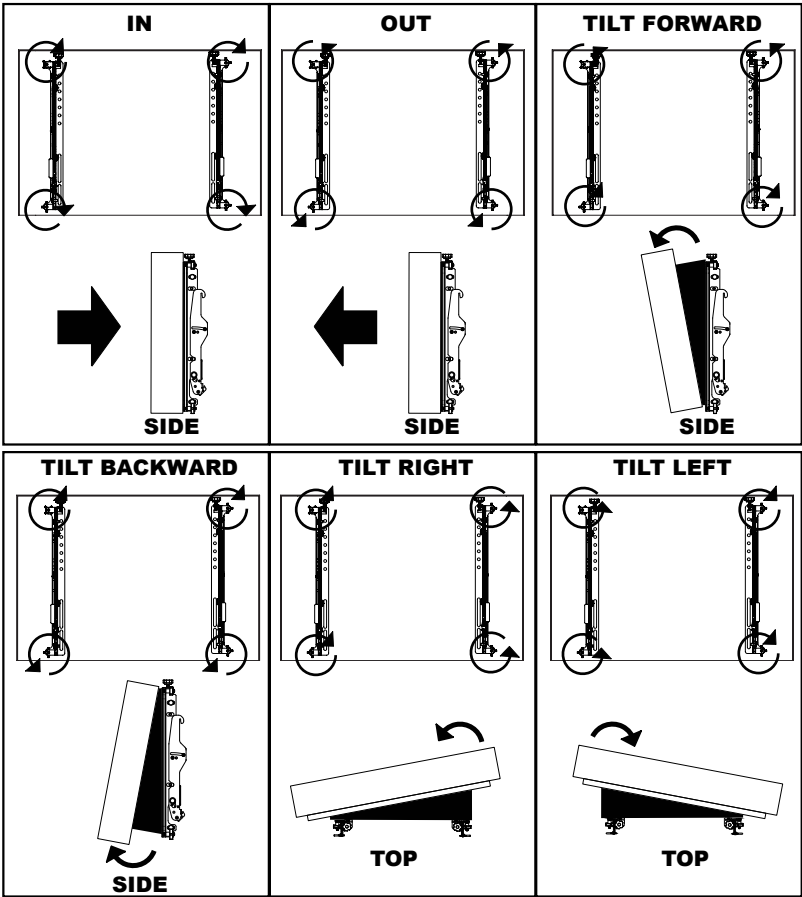

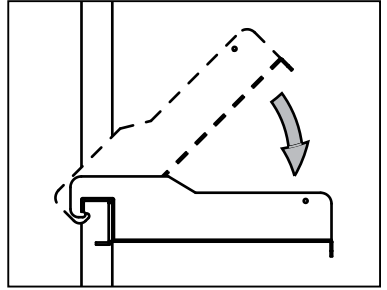
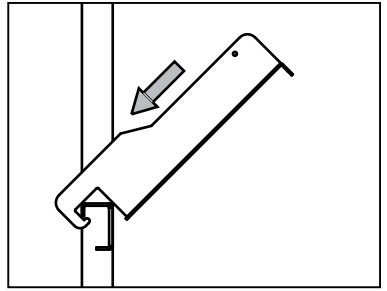
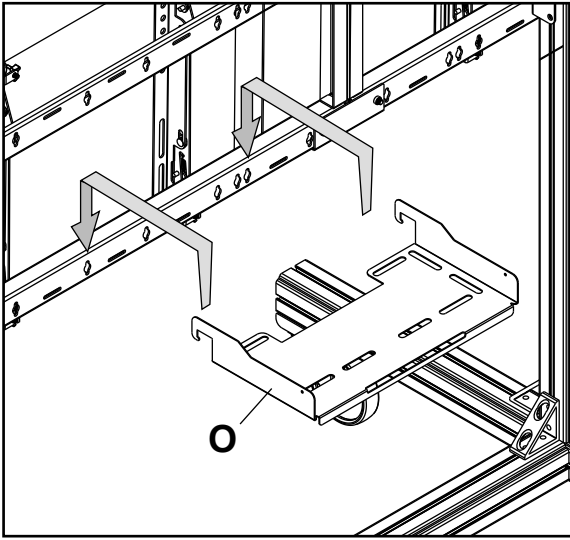

19-1

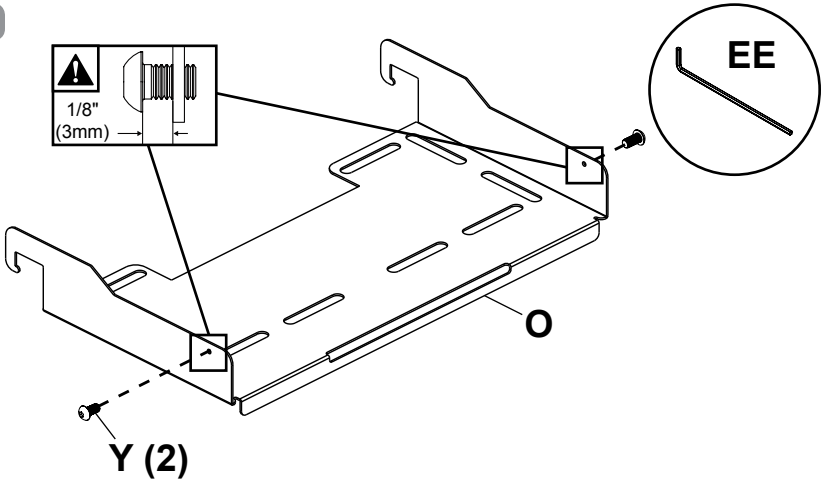

19-2

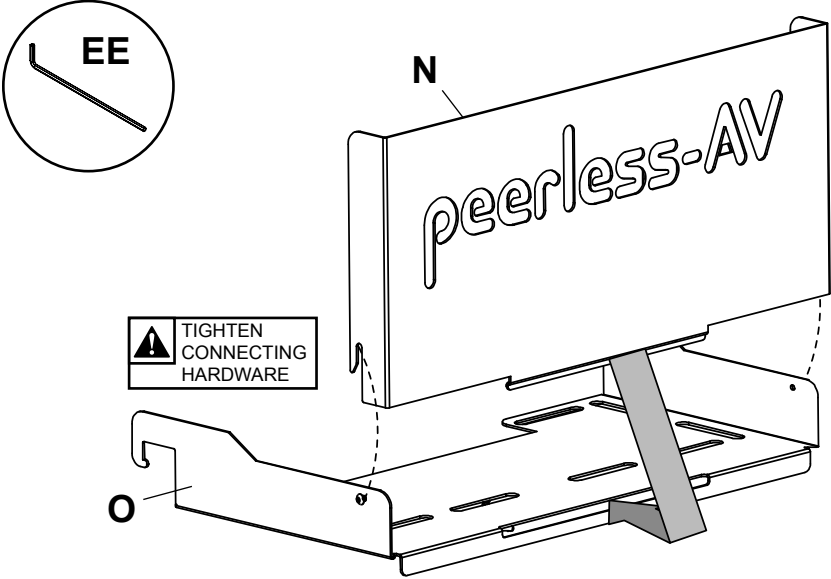

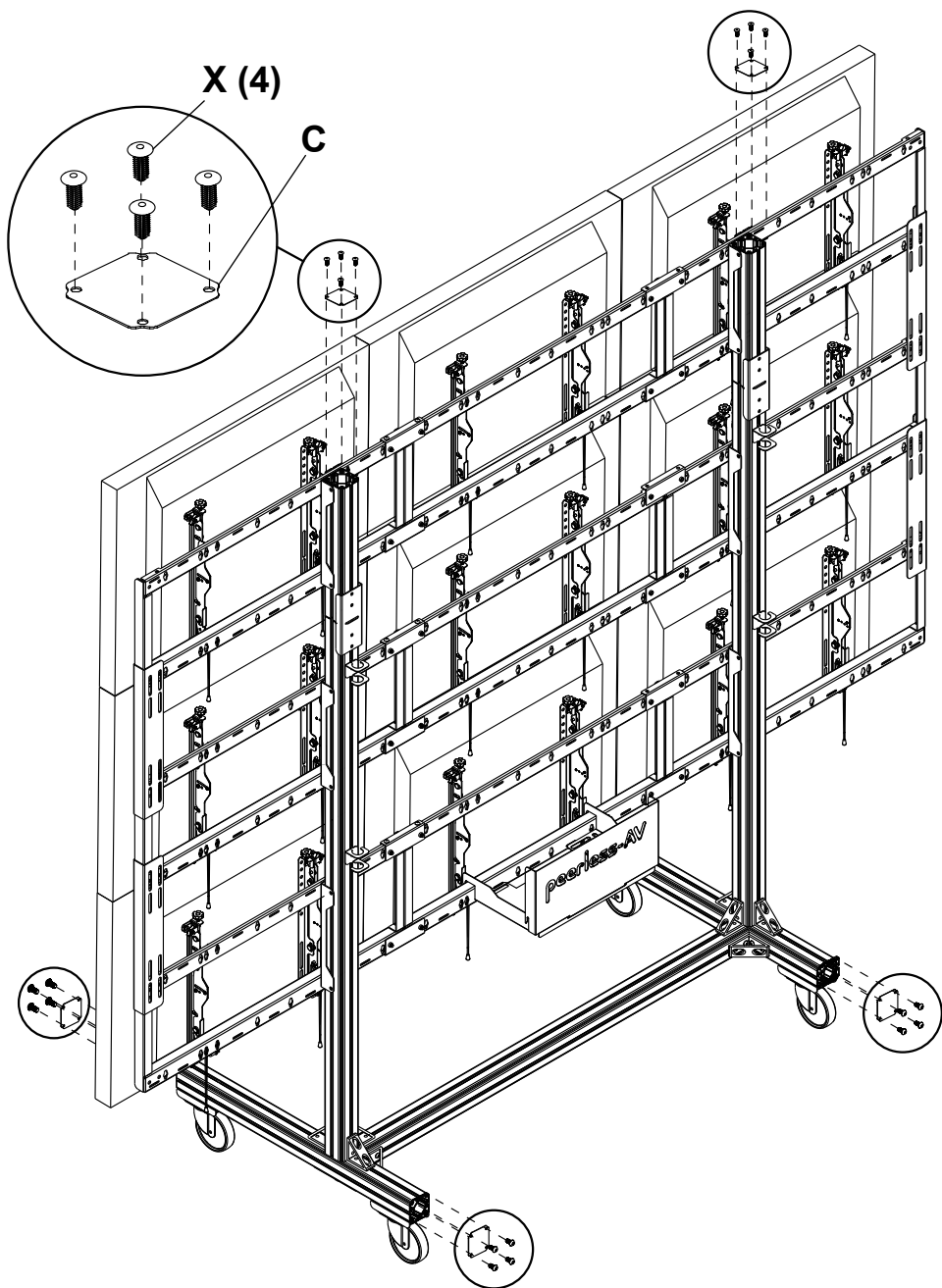

Route cables through cord brackets.

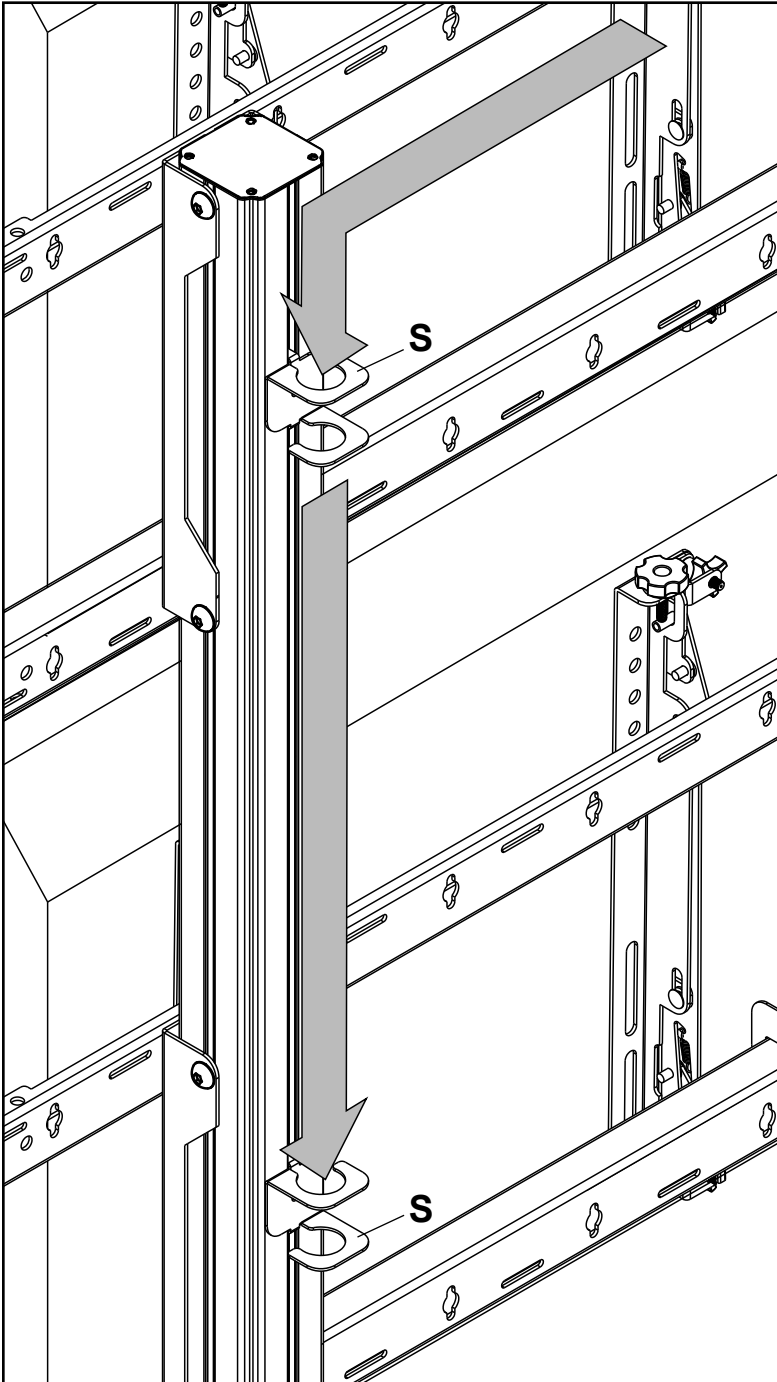

22-1 Display Removal

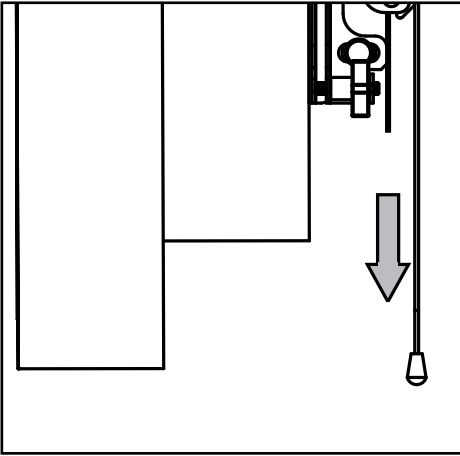

Pull down on bracket cords and hold.

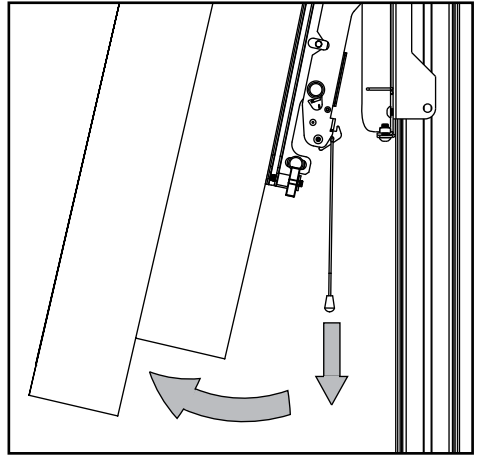

Swing screen away from cart and lift to remove.

22-2

Remove displays from top row first.

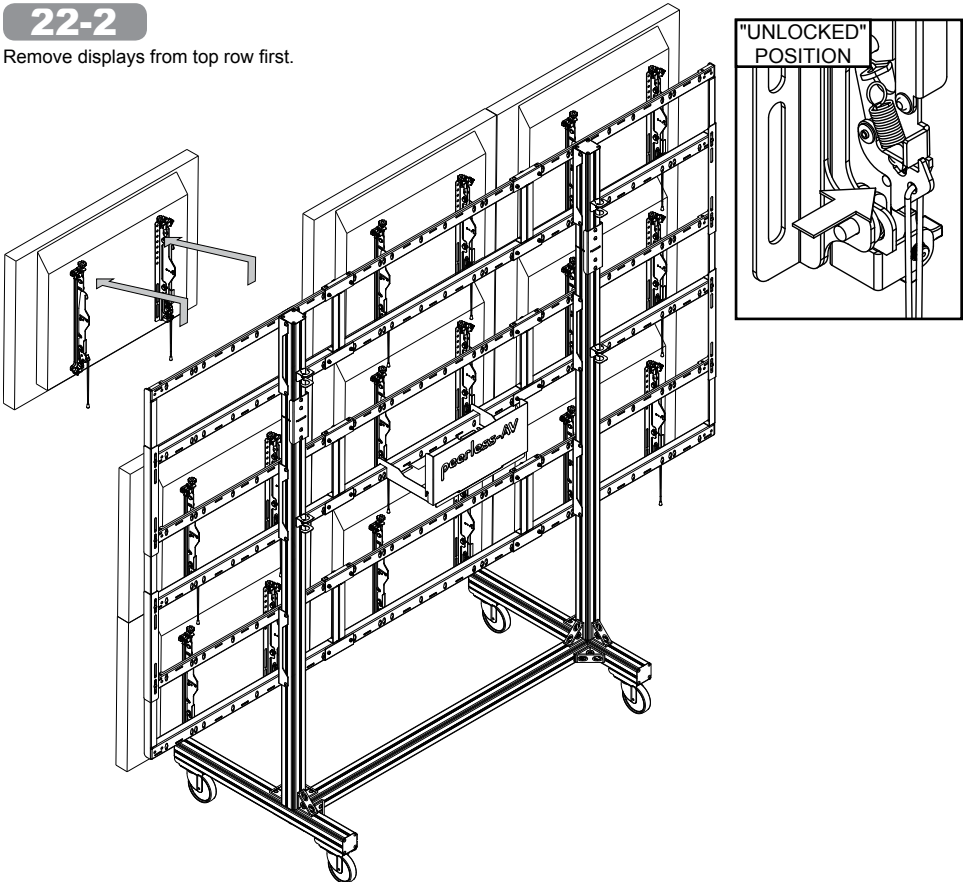

22-3

Remove displays from middle row second.

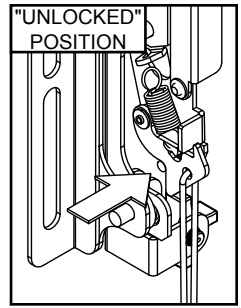
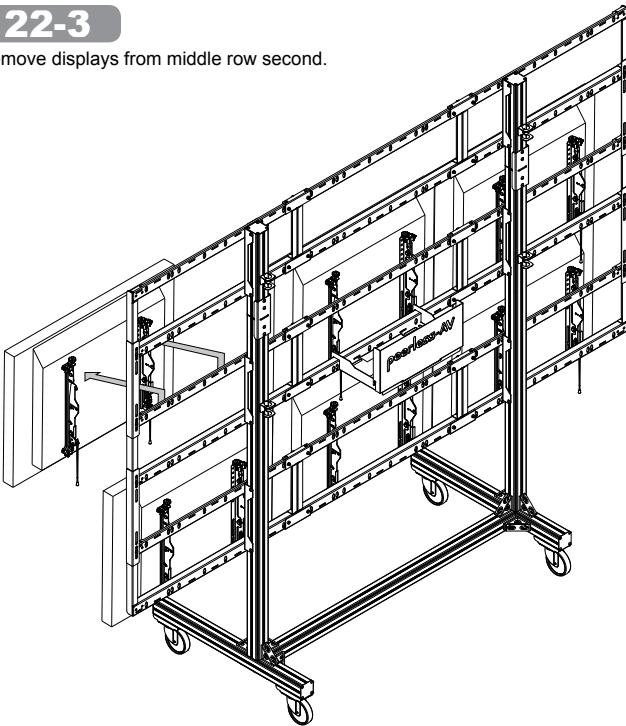

22-4

Remove displays from bottom row last.

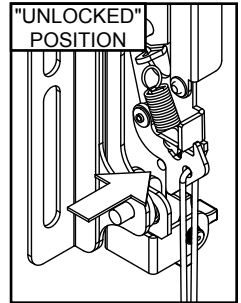
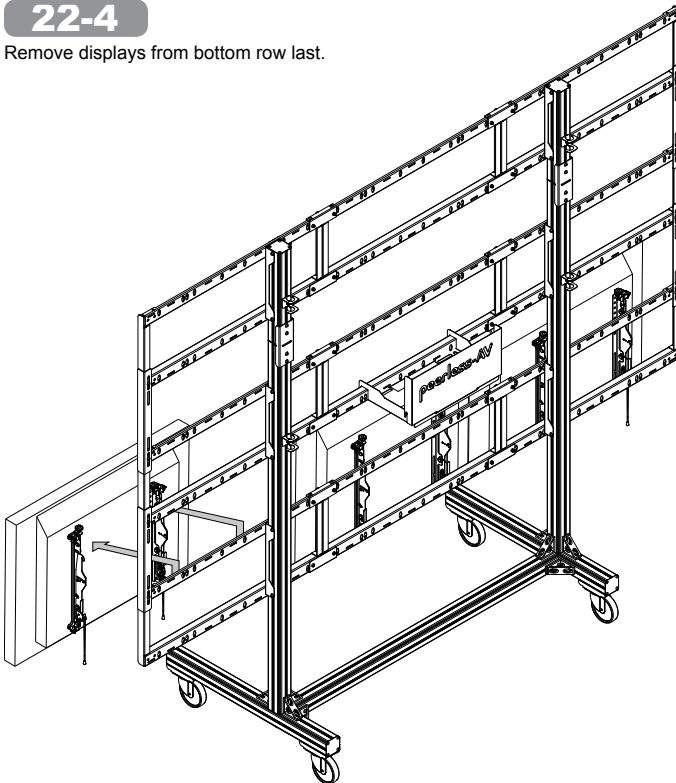

LIMITED FIVE-YEAR WARRANTY

Peerless Industries, Inc. ("Peerless-AV") warrants to original end-users that each Peerless-AV® mounting product will be free from defects in material and workmanship, under normal use, for the applicable warranty period (from date of the original installation of the product). At its option, Peerless-AV will repair or replace, or refund the purchase price of, any product which fails to conform with this warranty.

Any implied warranty of merchantability or fitness for a particular purpose shall be limited to the period of the express warranty set forth below.

In no event shall Peerless-AV be liable for incidental or consequential damages, whether or not secured by a security device which may be included with the product.

Some states do not allow limitations on how long an implied warranty lasts, or the exclusion of incidental or consequential damages, so the above limitation and/or the above exclusion may not apply to you.

This warranty does not cover damage caused by incorrect selection, installation or the failure to follow Peerless-AV instructions or warnings when installing, using or storing the product.

This warranty gives specific legal rights, and you may also have other rights which vary from state to state. To make a warranty claim in North America, contact Peerless-AV customer care at 1-800-865-2112. See complete global warranty information for regions outside North America at www.peerless-av.com/en-uk/customer-care/warranties-returns.

The logo for Peerless-AV features the word "peerless" in a bold, lowercase, red sans-serif font. To its right, the letters "AV" are enclosed in a red outline, with a registered trademark symbol (®) to the upper right of the "V".

Peerless-AV
2300 White Oak Circle
Aurora, IL 60502
Email: tech@peerlessmounts.com
Ph: (800) 865-2112
Fax: (800) 359-6500
www.peerless-av.com

© 2018, Peerless Industries, Inc.

Peerless-AV Europe
Unit 3 Watford Interchange,
Colonial Way, Watford, Herts,
WD24 4WP, United Kingdom
Customer Care
44 (0) 1923 200 100
www.peerless-av.com

© 2018, Peerless Industries, Inc.

Peerless-AV de Mexico
Ave de las Industrias 413
Parque Industrial Escobedo
Escobedo N.L Mexico 66062
Servicio al Cliente
01-800-849-65-77
www.peerless-av.com

© 2018, Peerless Industries, Inc.