

DS-C560-2X2 SmartMount® Portable Video Wall Cart 2x2 Configuration for 46" to 60" Displays up to 5" deep (127mm)

Product Specifications

	DIMENSIONS (W x H x D)	PRODUCT WEIGHT	LOAD CAPACITY	FINISH	AVAILABLE COLORS
DS-C560-2X2	80.79" x 81.14" x 36.10" (2052 x 2060 x 917mm)	163lb (74.1kg)	500lb (227kg) 125lb per display	Textured	Black

Package Specifications

	PACKAGE SIZE (W x H x D)	PACKAGE SHIP WEIGHT	PACKAGE UPC CODE	PACKAGE CONTENTS	UNITS IN PACKAGE
DS-C560-2X2	37.50" x 12.50" x 84.00" (953 x 318 x 2134mm)	185lb (84kg)	735029301516	Stand, casters, display adaptors and hardware	1

Accessories

- ACC-V800X:** Adaptor accessory for 600 x 400 and 800 x 400mm mounting patterns
- ACC310VWC4:** Video Wall Cart Accessory Feet - 4pk

All dimensions = inch (mm)

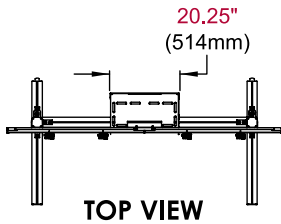

COMPATIBILITY FORMULA
Display height ≤ 36"
Display width + mount pattern width ≤ 80"

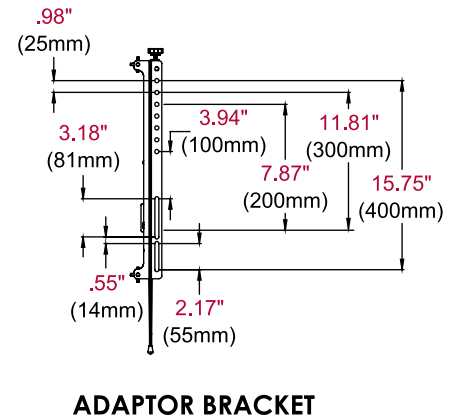
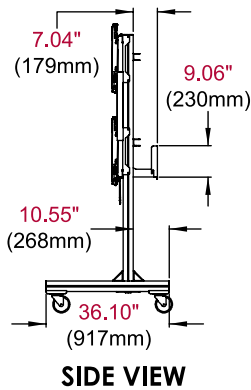
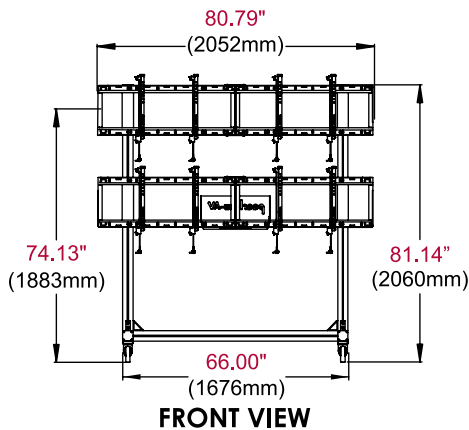

Architect Specifications

The Smartmount® Portable Video Wall Cart 2x2 Configuration shall be a Peerless-AV model DS-C560-2X2 and shall be located where indicated on the plans. Assembly and installation shall be done according to instructions provided by the manufacturer.

Visit peerless-av.com to see the complete line of AV solutions from Peerless-AV, including outdoor displays, wireless, kiosks, digital audio, display mounts, projector mounts, carts/stands, and a full assortment of accessories.

Peerless-AV
2300 White Oak Circle
Aurora, IL 60502 USA

(800) 865-2112
(630) 375-5100
Fax: (800) 359-6500

Peerless-AV EMEA
Unit 3 Watford Interchange
Colonial Way, Watford
Herts, WD24 4WP
United Kingdom
+44 (0) 1923 200100
Fax: +44 (0) 1923 200101

Peerless-AV Latin America
Ave de las Industrias 413
Parque Industrial Escobedo
Escobedo, N.L.,
Mexico 66062
+52 (81) 8384-8300
Fax: +52 (81) 8384-8360

