

SR575M



**Mounting Pattern**  
200 x 200 up to  
600 x 400mm



**Max Load**  
150lb (68.2kg) Display  
10lb (4.55kg) Per Shelf

**SMARTMOUNT.**

# Full Featured Flat Panel Cart

FOR 32" TO 75" DISPLAYS

The SR575M SmartMount® Full Featured Flat Panel Cart takes adjustability to the next level by making everyday usage more enjoyable. Height adjustment of the display and component shelf is a simple readjustment and can be done without removing the display. Non-marring bumpers on each corner of the cart make it easy to move from room-to-room, while the UL® certification ensures that it can be done safely.

- Includes a three-piece base and pre-assembled adaptor plate to reduce packaging waste and carton size
- Three-piece base also provides rigidity, stability, and quick assembly
- Integrated cable management protects, contains and conceals cables for a clean, professional installation
- Textured black powder coat finish helps to hide finger prints and dust
- Component shelf can be positioned anywhere along the column by simply lifting and repositioning
- Universal display adaptor fits mounting patterns from 200 x 200mm to 600 x 400mm and allows mounting in landscape or portrait orientation
- Cart includes (4) plastic base pads for instances when casters are not needed



Cable management allows cables to enter or exit anywhere along the column.



Corner bumpers protect walls and doorways from damage.



Please visit [peerless-av.com/en-us/patents](http://peerless-av.com/en-us/patents) for patent information.

# Model Numbers

**WARRANTY: Limited 5-year**

**SR575M** SmartMount® Full Featured Flat Panel Cart for 32" to 75" Displays

## Product Specifications

	DIMENSIONS (W X H X D)	PRODUCT WEIGHT	LOAD CAPACITY	FINISH	AVAILABLE COLORS
<b>SR575M</b>	35.79" x 68.27" x 30.00" (909 x 1734 x 763mm)	70lb (31.8kg)	150lb (68.2kg) Display 10lb (4.55kg) Per Shelf	Textured Powder Coat	Black

## Package Specifications

	PACKAGE SIZE (W x H x D)	PACKAGE SHIP WEIGHT	PACKAGE UPC CODE	PACKAGE CONTENTS	UNITS IN PACKAGE
<b>SR575M</b>	47.50" x 7.25" x 38.50" (1207 x 184 x 978mm)	83lb (37.7kg)	735029304265	Base, Left Leg, Right Leg, Aluminum Column, Universal Display Adaptor, Metal Component Shelf, (2) Swivel Casters, (2) Locking Swivel Casters, (4) Corner Bumpers, (4) Plastic Base Pads, Hardware & Instructions	1

## Accessories

<b>ACC310:</b> Leveling Feet Accessory	<b>ACC-VCS:</b> Video Conferencing Camera Shelf
<b>ACC316:</b> Safety Belt	<b>DSX750:</b> Media Player Storage
<b>ACC320:</b> Electrical Outlet Strip with Cord Wrap	<b>MIS995:</b> 800mm VESA® Adaptor
<b>ACC-BPR:</b> Bumper Accessory for Legs	<b>MOD-UNL2:</b> Large Universal Adaptor
<b>ACC-LA:</b> Laptop Arm	<b>RMI2C:</b> Rotational Mount Interface
<b>ACC-MS:</b> Metal Shelf	<b>ACSBR1:</b> Universal Sound Bar Mounting Kit for 32" to 70" TVs
<b>ACC-UCM:</b> Universal AV Component Mount	<b>ACSBR2:</b> Universal Sound Bar Mounting Kit for up to 80" Displays
<b>ACC-V900X:</b> 600, 800 and 900mm VESA® Adaptor	<b>ACC-SB2:</b> Universal UC/VC Sound Bar Mount

All dimensions = inch (mm)

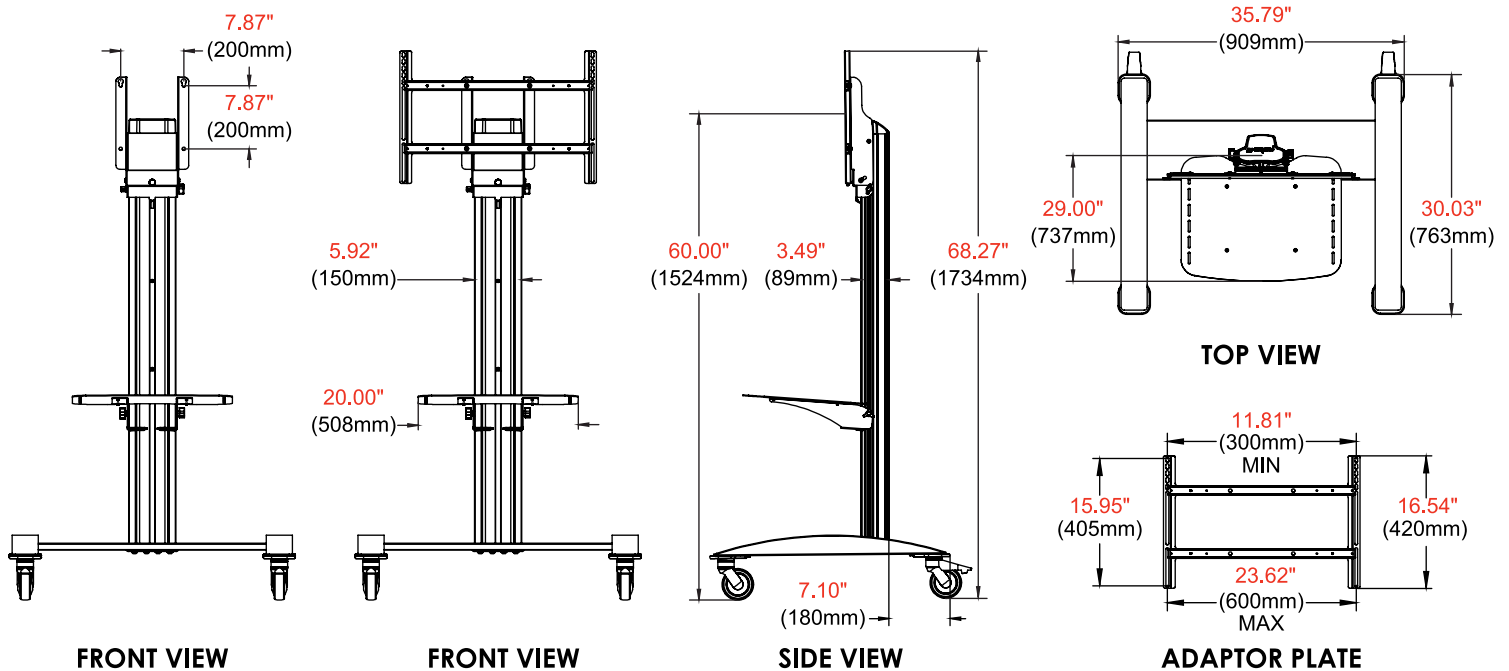

## Architect Specifications

The SmartMount® Full Featured Flat Panel Cart shall be a Peerless-AV model SR575M and shall be located where indicated on the plans. Assembly and installation shall be done according to instructions provided by the manufacturer.

Visit [peerless-av.com](http://peerless-av.com) to see the complete line of AV solutions from Peerless-AV, including outdoor displays, kiosks, display mounts, projector mounts, carts/stands, and a full assortment of accessories.

**Peerless-AV**  
2300 White Oak Circle  
Aurora, IL 60502  
USA  
**(800) 865-2112**  
**(630) 375-5100**

**Peerless-AV EMEA**  
Unit 2 Curo Park  
Frogmore, St. Albans  
Hertfordshire, AL2 2DD  
United Kingdom  
**+44 (0) 1923 200 100**

**Peerless-AV B.V.**  
Papendorpseweg 75  
3528 BJ Utrecht  
The Netherlands  
**+31 (0) 70 770 8037**

**Peerless-AV Latin America**  
Av. de las Industrias 413  
Parque Industrial Escobedo  
General Escobedo, N.L.,  
México, 66062  
**+52 (81) 8384-8300**

**peerless-AV®**  
Driving Technology Through Innovation

LIT-1244 rev.8